

# PLANNING ASSESSMENT REPORT

## Development Application for

The installation of a Telecommunications Facility at

928 Orton Road, Oldbury WA 6121

Lot 233 DP152813

Document prepared by Visionstream Pty Ltd

On behalf of Telstra Corporation Ltd

**Project Name: Byford West**

**Project No.: WA07145.02**

**June 2020**





Contents

Document Control ..... 3

1.0 Executive Summary ..... 4

    1.1 Site and Proposal Details..... 4

    1.2 Applicant Details ..... 4

2.0 Introduction ..... 5

3.0 Proposed Scope of Works ..... 5

4.0 Purpose of the Proposal..... 5

5.0 Mobile Telecommunications Networks..... 6

6.0 Site Selection Process ..... 6

7.0 Candidate Sites ..... 7

    7.1 Nominated Candidate ..... 10

    7.2 The Site..... 10

8.0 Federal Regulatory Framework ..... 11

    8.1 Telecommunications Act 1997 ..... 11

**8.2 Telecommunications (Low-impact Facilities) Determination 2018..... 12**

**8.3 Communications Alliance Ltd. Code C564: 2011 Industry Code – Mobile Phone Base Station Deployment ..... 12**

9.0 State Regulatory Framework..... 13

    9.1 Planning and Development Act 2005 ..... 13

    9.2 Statement of Planning Policy No. 5.2 - Telecommunications Infrastructures (WAPC) ... 13

10.0 Local Regulatory Framework ..... 17

    10.2 Shire of Serpentine-Jarrahdale Town Planning Scheme No.2 ..... 18

11.0 General Provisions..... 23

    11.1 Visual Impacts..... 23

    11.2 Heritage..... 24

    11.3 Flora and Fauna ..... 24

    11.4 Traffic ..... 24

    11.5 Access ..... 24

    11.6 Utilities..... 25

    11.7 Construction..... 25

    11.8 Bushfire ..... 25

12.0 Conclusion ..... 28

Appendix A - Certificate of Title ..... 30

Appendix B - Plans of the Proposal ..... 31

Appendix C - Environmental EME Report..... 32

Appendix D - Site Photographs ..... 33

Appendix F - Environment Analysis Report (EPBC) ..... 36

Appendix G - Refusal Notice for previous Candidate at 624 Kargotich Road Oakford .....37

**Document Control**

This Development Application is prepared by:

Visionstream Australia Pty Ltd

ABN 85 093 384 680

Postal Address:

20 Corporate Drive

Heatherton VIC 3202

**T** (03) 8547 7803

**W** [www.visionstream.com.au](http://www.visionstream.com.au)

<b>Document Control</b>				
Rev	Date	Status	Prepared by	Reviewed by
1.0	31/1/2020	Draft	Patrick Armstrong	Clinton Northey
2.0	16/6/2020	Draft	Clinton Northey	Emily Pink/Keith Coleman

**DISCLAIMER**

Visionstream Australia Pty Ltd does not accept any risk or responsibility for a third party using this document, unless written authorisation is provided by Visionstream Australia Pty Ltd.



## 1.0 Executive Summary

### 1.1 Site and Proposal Details

<b>Address of Site</b>	928 Orton Road, Oldbury WA 6121
<b>Legal Property Description</b>	Lot 233 DP152813
<b>Local Authority</b>	Shire of Serpentine Jarrahdale
<b>Planning Instrument</b>	Serpentine-Jarrahdale Town Planning Scheme No. 2
<b>Zone and Overlay</b>	Rural / No Overlays
<b>Use</b>	Telecommunications Facility
<b>Owner</b>	Algeri Nominees Pty Ltd

### 1.2 Applicant Details

<b>Applicant</b>	Telstra Corporation Limited ABN 051 775 556 C/- Visionstream Australia Pty Ltd	
<b>Contact Person</b>	Clinton Northey	0439 180 205 clinton.northey@visionstream.com.au
<b>Our Reference</b>	WA07145.02	

## 2.0 Introduction

This report has been prepared by Visionstream on behalf of Telstra as supporting information to a Planning Permit Application for the installation of a 40.65m high telecommunications facility at 928 Orton Road, Oldbury WA 6121 which is more formally known as Lot 233 on DP152813.

### Refer to Appendix 1 for Title details

All mobile phone network operators are bound by the operational provisions of the federal *Telecommunications Act 1997* (“The Act”) and the *Telecommunications Code of Practice 2018*. The *Telecommunications (Low-Impact Facilities) Determination 2018* allows for the upgrade of existing mobile phone network infrastructure without the consent of a relevant statutory authority.

In this instance the proposed development does not comply as a “Low Impact facility” under the definitions contained in the Commonwealth legislation. Therefore, it is subject to the provisions of the *WA Planning and Development Act 2005* and the provisions of the *Serpentine Jarrahdale Local Planning Scheme No. 1*.

## 3.0 Proposed Scope of Works

The proposal is inclusive of the following scope of works:

- Installation of one (1) 40m high monopole;
- Installation of one (1) triangular headframe;
- Installation of nine (9) new panel antennas (no greater than 2.8m in length);
- Installation of one (1) Telstra Equipment Shelter that is not more than 3m high with a base area of not more than 7.5m<sup>2</sup> at the base of the aforementioned tower;
- Installation of associated ancillary cabling and equipment;
- Installation of 8m by 11m chain-link fence with a 3m wide gate.

Refer to Plans attached in Appendix B for further details.

## 4.0 Purpose of the Proposal

The current proposal will form part of Telstra’s 4GX and 5G network solution to the Oldbury and Byford localities and will help to make Byford and the greater Serpentine-Jarrahdale Shire more accessible. It will deliver essential mobile services (voice calling, SMS), as well as live video calling, video-based content including; news, finance and sports highlights, and high-speed wireless internet – wireless broadband. With a coverage footprint of more than 2.1 million square kilometers and covering more than 99% of the Australian population. Telstra’s 5G is Australia’s largest and fastest national mobile broadband network and as such requires more network facilities, located closer together to ensure a high-quality signal strength to achieve reliable service and the fastest possible data transfer rates.

### By way of a background:

Mobile phones and mobile broadband devices continue to play an important role in the lives of Australians. This includes providing the fundamental ability to be in contact with family and friends, operating businesses more efficiently and effectively as well as dialling triple 0 during a natural disaster or other emergency.

Because of the ever-growing demand for more data and better reception, mobile phone carriers such as Telstra continually have to upgrade and expand mobile phone networks to increase capacity, to eliminate coverage blackspots and to keep up with the demands and expectations placed upon them by the community.

Recently people trying to access the network in Oldbury and Byford areas have notified Telstra of the need to improve the network and enhance the indoor coverage, a problem which is due to the increasing demands placed upon the existing network by mobile phone users, especially during peak periods.

As the incumbent telco Telstra knows how important access to modern telecommunications infrastructure is and in order to remedy the lack of mobile phone capacity and in building coverage in the aforementioned area. Telstra wishes to establish a new mobile telecommunications base station facility at 928 Orton Road, Oldbury WA 621.

## 5.0 Mobile Telecommunications Networks

A mobile telecommunications network is made up of multiple base stations covering a geographic area. They work by sending and receiving radio signals from their antennas to mobile phones and other mobile devices such as tablet computers, wireless dongles etc. Base stations are designed to provide service to the area immediately surrounding the base station which can be up to several kilometers in distance. Depending on the technical objectives of a base station, the physical characteristics of each telecommunications facility; such as its height, number and size of antennas, equipment, cabling etc will vary.

As a general rule, the higher the antennas of a base station the greater the range of coverage and the ability to relieve capacity issues. If this height is compromised then additional facilities, and thus more infrastructure, will be required for any given locality. The further a facility is located away from its technically optimum position the greater the compromise of the service. This may result in capacity and coverage problems and require additional or taller base stations to provide adequate service.

Each base station transmits and receives signals to and from mobile devices in the area. As the mobile device users move around their devices will communicate with the nearest base station facility to them at all times. If the users cannot pick up a signal, or the nearest base station is congested because it is already handling the maximum number of phone calls or maximum level of data usage, then the users may not be able to place a call, they may experience call “drop outs” or they might experience a slow data rate while attempting to download content.

There are three main factors that can cause the above:

- One may be too far away from a facility to receive a signal, or there may be objects blocking the signal from the nearest facility; such as hills and large trees. To ensure optimum service the radio signals transmitted between the facility’s antennas and mobile devices need to be unimpeded, maintaining a “line-of-sight” between them.
- The facility may be transmitting as much data and calls as it can handle. This can result in call drop-outs and slower data rates when too many users are connected to a facility at once.
- The depth of coverage, which affects the ability to make calls inside buildings, may be insufficient in some local areas.

## 6.0 Site Selection Process

Telstra commences the site selection process with a search of potential sites that meet the network’s technical requirements, with a view to also having the least possible impact on the amenity of the surrounding locality. Telstra applies and evaluates a range of criteria as part of this site selection process.

Telstra assesses the technical viability of potential sites through the use of computer modelling tools that produce predictions of the coverage that may be expected from these sites as well as from the experience and knowledge of the radio engineers.

There are also a number of other important criteria that Telstra uses to assess options and select sites that may be suitable for a proposed new facility. These take into account factors other than the technical performance of the site, and include:

- The potential to co-locate on an existing telecommunications facility.
- The potential to locate on an existing building or structure.
- Visual impact and the potential to obtain relevant town planning approvals.
- Proximity to community sensitive locations and areas of environmental heritage.



- The potential to obtain tenure at the site.
- The cost of developing the site and the provision of utilities (power, access to the facility and transmission links).

In making the proposal for this site at 928 Orton Road, Oldbury, Telstra has carefully weighed all of the aforementioned criteria. This analysis is detailed in the next section.

## 7.0 Candidate Sites

Telstra carefully examined a range of possible deployment options in the area before concluding that a new telecommunications facility at 928 Orton Road, Oldbury WA would be the most appropriate solution to provide necessary mobile phone coverage to the Oldbury and Byford localities.

Accordingly, this section of the report will demonstrate the following:

- Colocation opportunities and existing telecommunications infrastructure within proximity to the proposed installation; and
- An analysis of the locations considered when determining an appropriate location for a new telecommunications installation within the required coverage area.

### Colocation opportunities

The Communications Alliance Ltd. (formerly Australian Communications Industry Forum Ltd. - ACIF) *Industry Code C564:2018 – Mobile Phone Base Station Deployment* promotes the use of existing sites in order to mitigate the effects of the facilities on the landscape. It should also be noted that as a first preference Telstra attempts to utilise, where possible, any existing infrastructure or co-location opportunities.

Below is a map of existing and proposed telecommunications facilities surrounding Oldbury and surrounding localities – the blue marker indicates the location of the proposed telecommunications facility in Oldbury.

The grey marker to the South-West indicates where existing NBN tower is located. However, the existing NBN site is too far away to meet the capacity and in building coverage requirements of the existing project. Furthermore, there are no other nearby telecommunications facilities within the locality that would be capable of meeting the needs of the proposal. Accordingly, there is an identified lack of suitable telecommunications facilities within the vicinity of the proposed installation. As a result, there were no suitable colocation opportunities to provide the required capacity and in building coverage objectives.



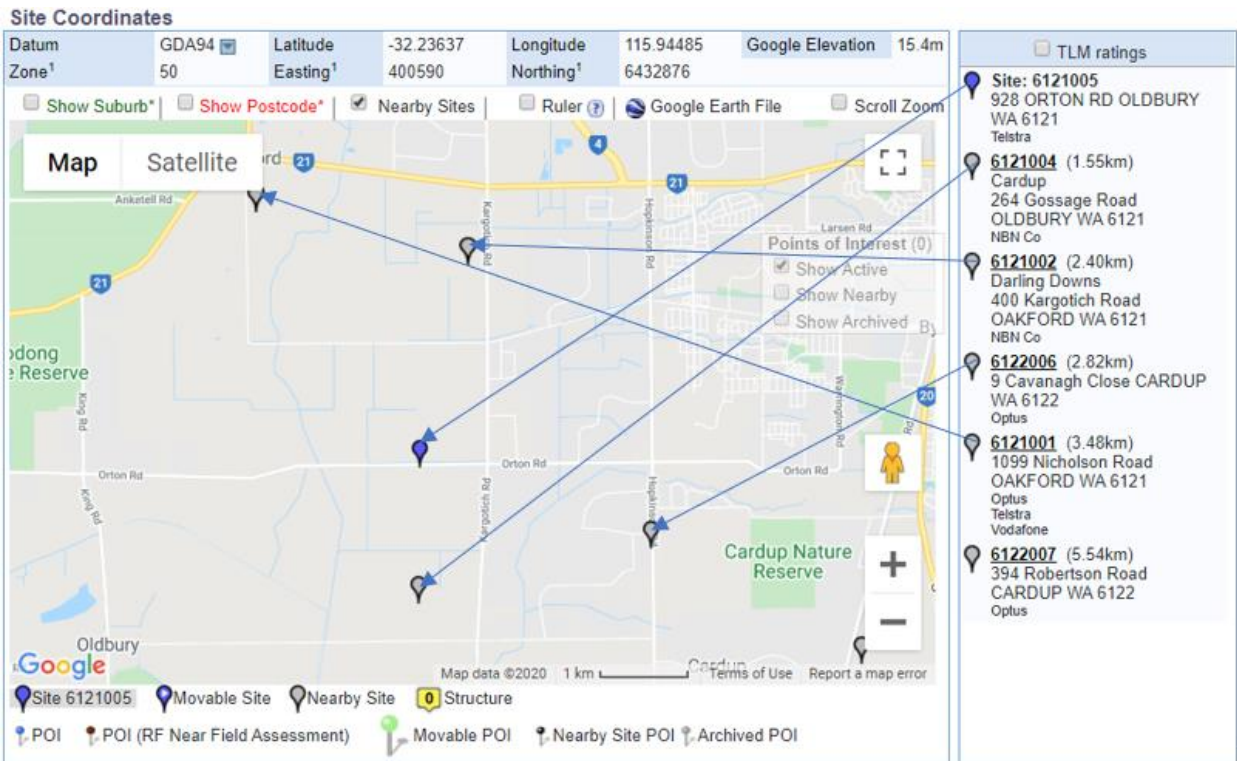

Figure 1: Location of nearby existing telecommunications facilities – Source: RFNSA, www.rfnsa.com.au

Candidates considered

The site selected is deemed to be the most optimal location to achieve the required capacity and coverage requirements and requires a 40m high telecommunications facility at 928 Orton Road, Oldbury (Candidate B). This is further outlined below along with the balance of alternative candidates considered as part of the site selection process

Candidate	Location	Proposal	Zoning	Description
Candidate A	400 Kargotich Road, Oakford, WA 6121  Lat: -32.215450 Long: 115.950766	Existing 45.0m NBN monopole	Rural	This candidate does not meet the coverage objectives of the project.

Candidate B	928 Orton Road, Oldbury, WA 6121 Lat: -32.236202 Long: 115.945518	Greenfield 40.0m monopole	Rural	Telstra's preferred Candidate and subject to this application.
Candidate C	624 Kargotich Road, Oakford, WA 6121 Lat: -32.235610 Long: 115.953021	Greenfield 40.0m monopole	Rural	This site was previously primed, however the Development Application (PA19/856) was refused by Council last year on the basis that it was located within prominent location.  Refer to Appendix G – Copy of Refusal Notice for this Candidate.

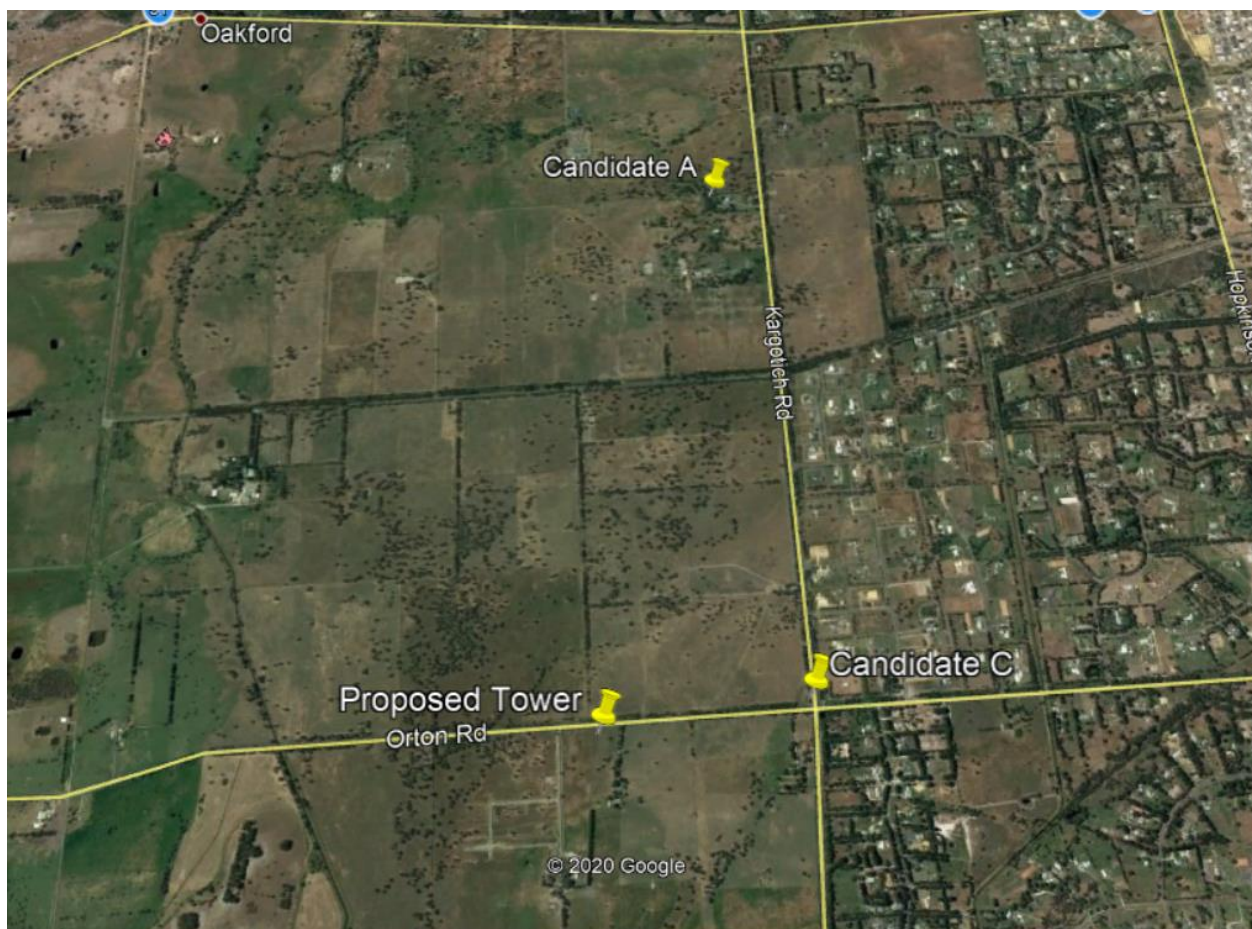

**Figure 2:** Location of Proposed Candidates, Source: Google Earth

## 7.1 Nominated Candidate

A preferred nominated candidate was selected for the proposed facility based on the capacity and coverage objectives, planning and environmental issues, potential community sensitive uses and engineering criteria as noted above. In this case, Candidate B (a new 40m monopole located at 928 Orton Road, Oldbury WA 6121) was considered the best option. This was based on the following:

- The site is appropriately located and sited to minimise visual and environmental impacts on the immediate and surrounding areas;
- Well setback from sensitive uses;
- The site will achieve the required capacity and indoor coverage objectives for the area;
- The site will help to make the Byford region 5G ready;
- The site will meet design and construction considerations; and
- The proposal operates within the regulatory framework of Commonwealth, State and Local Government.
- There is a willing landowner.

As stated above, the site selection process carefully considered environmental and visual constraints, existing and future land use characteristics, the orderly planning of the area and the design of the facility. On balance, it is considered that the location and height of the facility ensure optimal service provision to the area whilst minimizing any perceived impacts.

The proposed Telstra site has been sited and designed to minimise any adverse impact on the amenity of the surrounding locality. The site is located on cleared rural land away from sensitive sites such as Aboriginal heritage sites, schools and childcare centres.

As a result of the aforementioned points it is considered that the siting and design effectively responds to the landscape setting in the area.

It should be noted however that this site as discussed in section 7 is the back up candidate to the previous location at the Telstra Exchange at 624 Kargotich Road, Oakford that was refused by Council in October in 2019.

## 7.2 The Site

The subject site is located at 928 Orton Road, Oldbury WA 6121. The legal description of the property is Lot 141 on Plan 192052. A copy of the Certificate of Title has been attached for information purposes (**Appendix 1 – Certificate of Title**).

The land is owned by Algeri Nominees Pty Ltd.

The aforementioned land is zoned 'Rural' under the provisions of the Shire of Serpentine Jarrahdale *Local Planning Scheme No. 2* – refer to **Section 10.1** for additional information on planning schemes and map images.

The site will be accessed via Orton Road through an established crossover. The adjoining properties are characterised by Rural/Agricultural land uses.

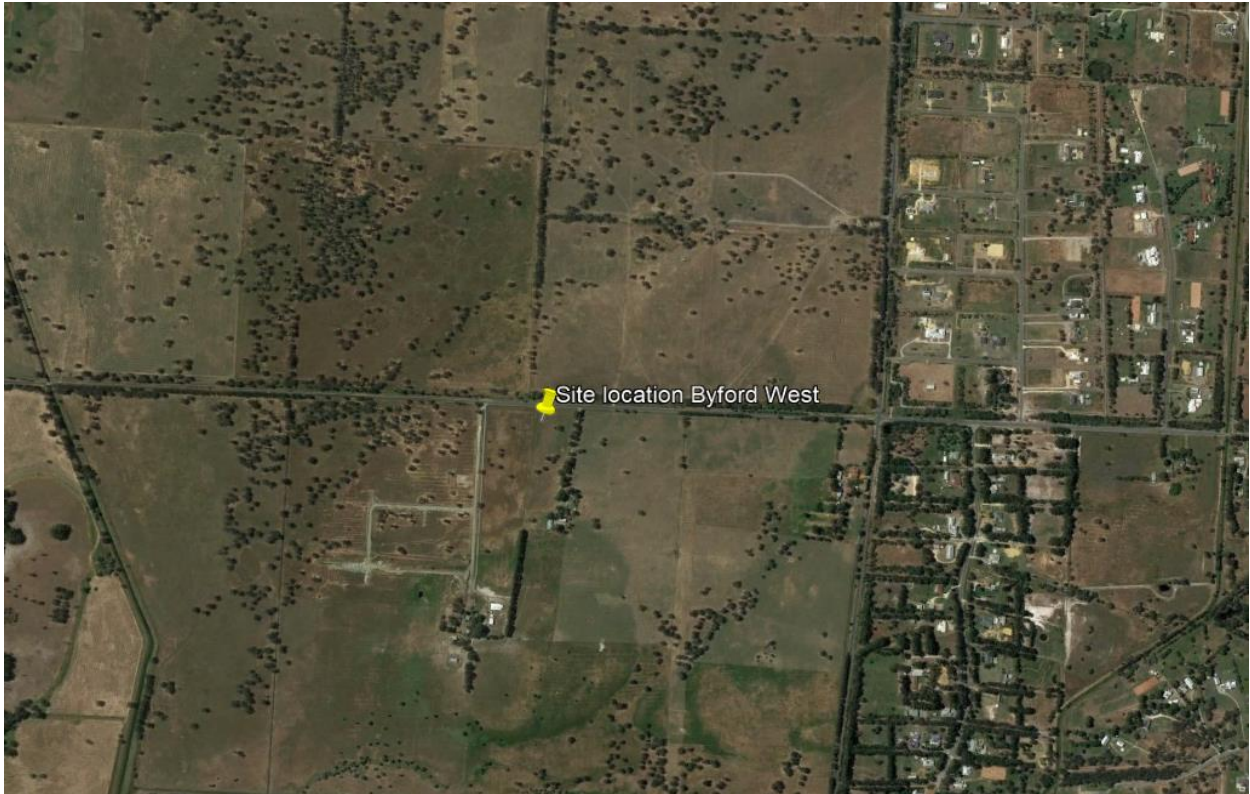

**Figure 3: Proposed Telstra Site – 928 Orton Road, Oldbury** (Source: Google Earth)

Appropriate setbacks to any identified sensitive sites such as schools and heritage areas have been considered and achieved during the detailed siting of the facility.

The site is located outside of areas of environmental significance as defined by The *Telecommunications (Low-Impact Facilities) Determination 2018*.

In addition, the proposed base station has been sited within rural zoned land in order to diminish any negative effects of the proposal upon the surrounding and more densely populated Residential zoned areas. Furthermore, the proposal will be setback from Orton Road within an established Rural property with the closest neighbouring dwelling being approximately 450 metres south west of the proposal’s location. In siting the facility within this area, it is hoped that this will lessen any potential impacts upon the visual amenity of the area and help to keep the facility hidden away from public view (refer to photomontages provided).

## 8.0 Federal Regulatory Framework

The following information provides a summary of the Federal legislation relevant to telecommunications development proposals.

### 8.1 Telecommunications Act 1997

The *Telecommunications Act 1997* (the Act) came into operation on 1<sup>st</sup> July 1997. The Act provides a system for regulating telecommunications and the activities of carriers and service providers.

Under the Act, telecommunications carriers are no longer exempt from State and Territory planning laws except in three limited instances:

1. There are exemptions for the inspection of land, maintenance of facilities, installation of “low impact facilities”, subscriber connections and temporary defense facilities. These exemptions are detailed in the *Telecommunications (Low-impact Facilities) Determination 2018* and these exemptions are subject to the *Telecommunications Code of Practice 2018*;

2. A limited case-by-case appeals process exists to cover the installation of facilities in situations of national significance; and
3. There are some specific powers and immunities from the previous *Telecommunications Act 1991*.

## 8.2 Telecommunications (Low-impact Facilities) Determination 2018

The *Telecommunications (Low-impact Facilities) Determination 2018* came into effect in March 2018.

The *Determination* contains a list of Telecommunications Facilities that the Commonwealth will continue to regulate. These are facilities that are essential to maintaining telecommunications networks and are unlikely to cause significant community disruption during their installation or operation. These facilities are therefore considered to be 'Low-impact' and do not require planning approval under State or Territory laws.

The proposed facility at 928 Orton Road, Oldbury does not fall under the *Telecommunications (Low-impact Facilities) Determination 2018* and, therefore, requires approval under State Planning Legislation.

## 8.3 Communications Alliance Ltd. Code C564: 2011 Industry Code – Mobile Phone Base Station Deployment

The new Communications Alliance Ltd. C564:2018 *Industry Code – Mobile Phone Base Station Deployment* (referred to as the *Deployment Code*) replaced the Australian Communications Industry Forum (ACIF) '*Industry Code - Deployment of Mobile Phone Network Infrastructure*' (more commonly referred to as the *ACIF Code*) in July 2012. The purpose of the revisions incorporated in the new *Deployment Code* is to provide certainty and clarity for all parties in the implementation of the Code. For example, with regard to the consultation process with councils and communities, and with regard to providing and updating RF EMR Health and Safety information, reports and signage in keeping with relevant standards.

Similar to the *ACIF Code*, the new *Deployment Code* cannot change the existing regulatory regime for telecommunications at Local, State or Federal levels. However, it supplements the existing obligations on Carriers, particularly in relation to community consultation and the consideration of exposure to radio signals, sometimes known as electromagnetic energy (EME or EMR).

The *Code* imposes mandatory levels of notification and community consultation for sites complying with the *Telecommunications (Low-impact Facilities) Determination 2018*. It identifies varying levels of notification and/or consultation depending on the type and location of the proposed infrastructure.

The subject proposal, not being designated a 'Low-impact' Facility', is not subject to the notification or consultation requirements associated with the *Deployment Code*. These processes are handled within the relevant State and Local consent procedures.

Nevertheless, the intent of the *Code* is to ensure Carriers follow a 'precautionary approach' to the siting of infrastructure away from sensitive land uses and this approach has been followed in the selection of this site, as demonstrated in the *Deployment Code* section 4.1 Precautionary Approach Checklist. This checklist will be uploaded to the RFNSA website, reference number 6121005.

Included in the section 4.1 Checklist is a statement of how the public's exposure to EME from the site has been minimised. All emissions from the site will be well within the requirements of the relevant Australian Standard. Details of this standard are contained in the following section.

This site has been selected and designed to comply with the requirements of the *Deployment Code* in so much as the precautionary approach has been adhered to and, as a result, the best design solution has been achieved.



## 9.0 State Regulatory Framework

The following information provides a summary of the State legislation/guidelines relevant to telecommunications development proposals.

### 9.1 Planning and Development Act 2005

The Minister of Planning and Infrastructure has ultimate authority for town planning in Western Australia. Development within Western Australia is controlled by the *Planning and Development Act 2005* through the application of environmental planning instruments. Under the *Planning and Development Act 2005*, the Western Australian Planning Commission (WAPC) is the responsible authority for land use planning and development matters and this report seeks to demonstrate compliance with the WAPC and other items of relevant legislation which pertain to the subject application.

### 9.2 Statement of Planning Policy No. 5.2 – Telecommunications Infrastructures (WAPC)

The WAPC *Statement of Planning Policy No. 5.2 – Telecommunications Infrastructure* (SPP 5.2) provides a framework for the preparation, assessment and determination of applications for planning approval of telecommunications facilities within the context of the planning system of Western Australia. *Planning Policy 5.2* states that ‘telecommunications infrastructure should be located, sited and designed in accordance with the following Guiding Principles’.

Principles	Comments	Complies
There should be a co-ordinated approach to the planning and development of telecommunications infrastructure, although changes in the location and demand for services require a flexible approach.	Telstra undertakes a carefully co-ordinated and planned approach to the development of their network.	✓
Telecommunications infrastructure should be strategically planned and co-ordinated, similar to planning for other essential infrastructure such as networks and energy supply.	The proposed facility is strategically planned and co-ordinated to ensure that the facility will provide high level capacity and coverage to the Byford/Oldbury locality. With the other telecommunications facilities within the vicinity (these being RFNSA No. 6330018 NBN Co).  The proposed facility will not only provide much needed relief to the other facilities within the area but will also provide colocation opportunities for other carriers.	✓
Telecommunications facilities should be located and designed to meet the communication needs of the community.	With only one facility present within the Byford area, the proposal has been located and designed to meet the growing communication needs of the community within the area.	✓
Telecommunications facilities should be designed and sited to minimise any potential adverse visual impact on the character	The proposed 40m monopole has been sited to maintain the primary use of the land whilst considering the impact to the surrounding locality. The site carefully considered	✓



<p>and amenity of the local environment, in particular, impacts on prominent landscape features, general views in the locality and individual significant views.</p>	<p>environmental and visual constraints, existing and future rural land uses. Given the rural uses of the site at Orton Road and the surrounding area it is seen that the proposed facility will have minimum visual impact.</p> <p>On balance, it is considered that the location and height of the facility ensure optimal service provision to the area whilst minimising any perceived impacts.</p>	
<p>Telecommunications facilities should be designed and sited to minimise impacts on areas of natural conservation value and places of heritage significance or where declared rare flora are located.</p>	<p>A desktop study of the proposed site indicated that it is not affected by any heritage listings nor is it in close proximity to any heritage listings. As the land is already cleared there should be no impact on the natural environment or its surrounds.</p>	✓
<p>Telecommunications facilities should be designed and sited with specific consideration of water catchment protection requirements and the need to minimise land degradation.</p>	<p>Prior to the commencement of work Telstra will undertake such measures as deemed necessary by Council to effectively protect water catchments within the immediate area.</p>	✓
<p>Telecommunications facilities should be designed and sited to minimise adverse impacts on the visual character and amenity of residential area.</p>	<p>The land is situated within the Rural Zone and as such there is no visual character or negative amenity presented to any residential area. The closest dwelling is approximately 450 metres south-west of the proposed site, which can be identified as a rural block.</p> <p>Furthermore, Telstra has selected a site and location that seeks to minimise any perceived negative impacts on the visual amenity of the area, particularly when viewed from residential areas. The proposed 40m monopole will remain unpainted (dull grey in colour) which blends in with the sky.</p>	✓
<p>Telecommunications cables should be placed underground, unless it is impractical to do so and there would be no significant effect on visual amenity or, in the case of regional areas, it can be demonstrated that there are long-term benefits to the community that outweigh the visual impact.</p>	<p>Overhead cabling is not proposed for this site.</p>	✓
<p>Telecommunications cables that are installed overhead with other infrastructure such as electricity cables should be removed and placed underground when it can be demonstrated and agreed by the carrier that it is technically feasible and practical to do so.</p>	<p>This principle does not apply to the subject of this application.</p>	N/A



<p>Unless it is impractical to do so telecommunications towers should be located within commercial, business, industrial and rural areas and areas outside identified conservation areas.</p>	<p>The proposed site is zoned 'Rural' as identified by the Shire of Serpentine Jarrahdale <i>Local Planning Scheme No. 2</i>. Given the nature of the land the proposed facility will be located in the desired zoning.</p>	<p style="text-align: center;">✓</p>
<p>The design and siting of telecommunications towers and ancillary facilities should be integrated with existing buildings and structures, unless it is impractical to do so, in which case they should be sited and designed so as to minimise any adverse impact on the amenity of the surrounding area.</p>	<p>As per Section 7 of this report, no suitable opportunities for co-location were identified in the area and it has been identified that the proposed Telstra site location is seen as the preferred site location. Colocation was investigated; however, the locations were either an existing Telstra site which is too far from the subject area to meet the coverage objectives of the proposal or the existing NBN tower which does not meet the coverage requirements of the project.</p> <p>Given the nature of the surrounding land uses it is foreseen that the proposed telecommunications facility will not present an out of character visual effect</p>	<p style="text-align: center;">✓</p>
<p>Co-location of telecommunications facilities should generally be sought, unless such an arrangement would detract from local amenities or where operation of the facilities would be significantly compromised as a result.</p>	<p>As per Section 7 of this report, no suitable opportunities for co-location were identified in the area and it has been identified that the proposed Telstra site location is seen as the preferred site location. Colocation was investigated; however, the locations were either an existing Telstra site which is too far from the subject area to meet the capacity and coverage objectives of the proposal or the existing NBN tower which does not meet the capacity and coverage requirements of the project.</p>	<p style="text-align: center;">✓</p>
<p>Measures such as surface mounting, concealment, colour co-ordination, camouflage and landscaping to screen at least the base of towers and ancillary structures, and to draw attention away from the tower, should be used, where appropriate, to minimise the visual impact of telecommunications facilities.</p>	<p>Telstra has selected a site and location that seeks to minimise any perceived negative impacts on the visual amenity of the area, particularly when viewed from the road or neighbouring properties. The monopole will remain unpainted (dull grey in colour) which blends in with the sky. Furthermore, the proposed subject site maintains suitable separation distance from surrounding residential areas.</p>	<p style="text-align: center;">✓</p>
<p>Design and operation of a telecommunications facility should accord with the licensing requirements of the Australian Communications Authority, with physical isolation and control of public access to emission hazard zones and use of minimum power levels consistent with quality services.</p>	<p>Telecommunications facilities include radio transmitters that radiate electromagnetic energy (EME) into the surrounding area. The levels of these electromagnetic fields must comply with safety limits imposed by the Australian Communications and Media Authority (ACMA, previously ACA). All Telstra installations are designed to operate within these limits.</p>	<p style="text-align: center;">✓</p>
<p>Construction of a telecommunications facility</p>	<p>During construction Telstra contractors will endeavour to minimise the impact of their works</p>	<p style="text-align: center;">✓</p>





(including access to a facility) should be undertaken so as to minimise adverse effects on the natural environment and the amenity of users or occupiers of adjacent property and to ensure compliance with relevant health and safety standards.	on the amenity of nearby residents and on the surrounding environment. As the proposed site is located in a rural area, adverse effects on nearby properties will be minimal. Following construction, maintenance (excluding emergency repair work) activities should not interfere with the amenity of users. All Health and Safety standards will be adhered to.	
---	--	--

Under section 5.1.1 of the *State Planning Policy 5.2: Telecommunications Infrastructure Policy* the West Australian Planning Commission provides a set of measures in assessing the visual impact of a proposed telecommunications facility.

An assessment of these guidelines below has found that the proposed Telstra Mobile Phone Base Station is compliant with the intent and requirements of the *State Planning Policy 5.2: Telecommunication Infrastructure Policy*.

Measures	Comments	Complies
Be located where it will not be prominently visible from significant viewing locations such as scenic routes, lookouts and recreation sites;	The proposed location is within a rural area, with the facility being located 27m off the northern boundary of the subject site. There are no scenic routes, lookouts and or recreational areas within the vicinity of the proposed facility that will be impacted by the proposal.  Photomontages have been provided as part of this application to indicatively show how the facility will be viewed from Orton Road.	✓
Be located to avoid detracting from a significant view of a heritage item or place, a landmark, a streetscape, vista or a panorama, whether viewed from public or private land;	Telstra has selected a site and location that seeks to minimise any perceived negative impacts on the visual amenity of the area, particularly when viewed from residential areas. The proposed 40m monopole will remain unpainted (dull grey in colour) which blends in with the sky. Furthermore, the proposed subject site maintains suitable separation distance from rural/residential dwellings.	✓
Not be located on sites where environmental, cultural heritage, social and visual landscape values may be compromised;	There are no known items of environmental, cultural or social significance located on the proposed site. Any visual impact has been mitigated through a variety of design elements.	✓
Display design features, including scale, materials, external colours and finishes that are sympathetic to the surrounding landscape;	The proposed 40m monopole has been sited to maintain the primary use of the land whilst considering the impact to the surrounding locality. The site carefully considered environmental and visual constraints, existing and future land use characteristics, the orderly planning of the area and the design of the facility. On balance, it is considered that the location and height of the facility ensure optimal service provision to the area whilst minimizing any perceived impacts	✓
Be located where it will facilitate continuous network coverage and/or improved telecommunications services to the community;	Telstra has identified mobile phone coverage blackspots in the Byford locality.  The proposed location at 928 Orton Road, Oldbury will provide improved and continuous	✓

	<p>capacity and coverage to the locality and will also provide other carriers with the opportunity to co-locate their infrastructure in the future.</p>	
<p>Telecommunications infrastructure should be co-located and whenever possible: Cables and lines should be located within an existing underground conduit or duct; and Overhead lines and towers should be co-located with existing infrastructure and/or within an existing infrastructure corridor and/or mounted on existing or proposed buildings.</p>	<p>As per Section 7 of this report, no suitable opportunities for co-location were identified in the area and it has been identified that the proposed Telstra site location is seen as the preferred site location. Colocation was investigated; however, the locations were either an existing Telstra site which is too far from the subject area to meet the capacity and coverage objectives of the proposal or the existing NBN tower which does not meet the capacity and coverage requirements of the project.</p> <p>Therefore, it has been identified that the proposed Telstra site location is seen as the preferred site location. As mentioned previously, the proposed Telstra monopole will also provide other carriers with the opportunity to co-locate their infrastructure in the future.</p> <p>As this is a greenfield site there is no option to utilise existing underground conduit or ducts. Overhead lines are not applicable to this application.</p>	<p style="text-align: center;">✓</p>

## 10.0 Local Regulatory Framework

The following information provides a summary of the local provisions relevant to telecommunications development proposals.

### 10.1 Shire of Serpentine Jarrahdale Planning Scheme & Relevant Policies

The Shire of Serpentine Jarrahdale sets out its objectives in 'Scheme objectives', in the following:

- a) to secure the amenity, health, safety and convenience of the inhabitants of the District;
- b) to zone land for the purpose described in the Scheme so as to promote the orderly development of the land by making suitable provisions for land use;
- c) to reserve land for future and present public use;
- d) to make provisions for the conservation and preservation of places of natural beauty, historic buildings and objectives of historic or scientific interest.
- e) To create a pedestrian and vehicular circulation system together with landscape environment which complements the wide range of activities carried on and proposed to be carried in the District.
- f) To encourage coordinated development of the District in accordance with the guidelines set out in the planning studies adopted by the Council for particular areas or the District as a whole.

To make provision for other matters incidental to town planning and land use management.

## 10.2 Shire of Serpentine-Jarrahdale Town Planning Scheme No.2

The *Serpentine-Jarrahdale Town Planning Scheme No 2* provides the legal basis for planning in the Shire’s local government area.

The proposed site and the surrounding area have a large portion which is zoned ‘Rural’ as shown in **Figure 4** below.

For the purposes of this proposal the Principal Designated Use of the property is ‘Rural’. Telecommunications infrastructure is listed under Table 1, Use Classes 8, Cross reference AA. Cross reference AA means that Council may, at its discretion, permit the use. The proposed telecommunications facility at 928 Orton Road, Oldbury WA 6121 complies with the objectives of the *Scheme (Objectives a to g)* is planned to be sited so as to ensure it limits any negative impacts on the amenity of the area.

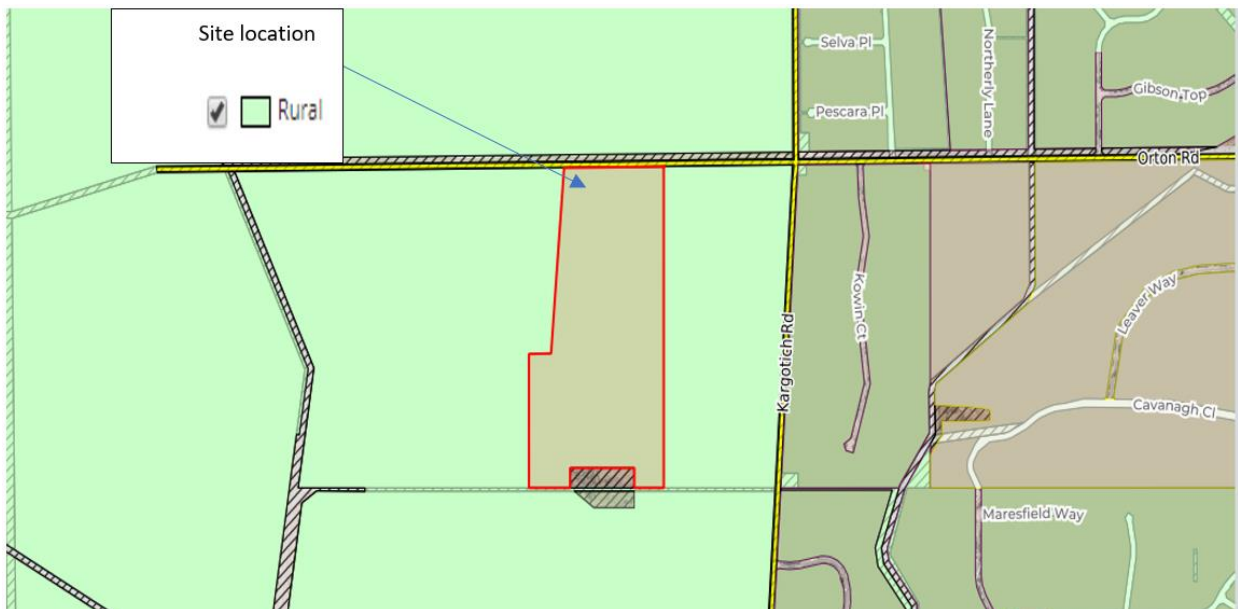

**Figure 4: Zoning Map- Rural (Shire of Serpentine Jarrahdale Town Planning Scheme No. 2)** (Source: Shire of Serpentine Jarrahdale Planning Maps)

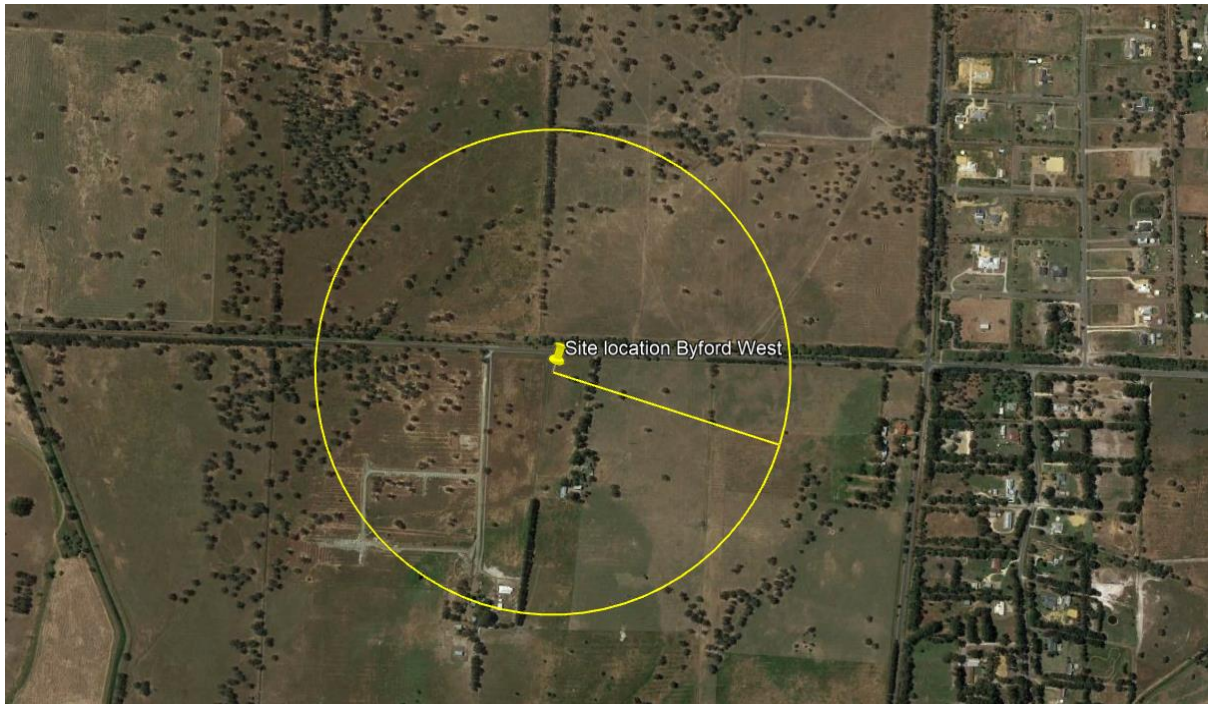

**Figure 5:** Aerial Photo of Proposed Site Showing 500m Radius (Source: Google Earth)

The proposal has been sited to retain the land for its current use and minimises visual impacts upon the amenity of the area by being placed on a rural site where it is also surrounded by other established rural blocks. The detailed siting has been undertaken to ensure the primary use of the land and any potential future use of surrounding land is not negatively impacted upon.

**Local Planning Policy: 4.6 Telecommunications Infrastructure**

**Assessment:**

<b>Objectives</b>	<b>Applicant Comment</b>
<p><b>Objective 1</b></p> <p>To facilitate the coordinated development of Telecommunications Infrastructure in appropriate locations within the Shire</p>	<p>The location has been strategically sited to enable effective radio frequency, whilst at the same time to lesson any adverse impact both in an environmental and visual sense.</p>
<p><b>Objective 2</b></p> <p>To minimise adverse impacts of Telecommunications Infrastructure, including amenity environment and heritage</p>	<p>The location of the proposal has been strategically sited within a rural area to allow setbacks from Orton Road as well as neighbouring dwellings within the vicinity. The location of the site is not subject to any heritage or cultural significance and is not located within an environmentally sensitive area.</p>

**Policy Provisions-Colocation**

<p>1. In order to provide for future co-location, all Telecommunications Infrastructure must be designed in such a manner as to permit at least three carriers to co-locate</p>	<p>Given the height and type of monopole proposed the proposal will provide other carriers with the opportunity to co-locate their infrastructure in the future on the site.</p>
---	--



<p>1.2 Carriers must collocate onto existing towers/monopoles, other existing structures or replace existing structures were possible. If there is an existing facility in the locality and the Carrier chooses not to co-locate with that facility, the applicant will be required to demonstrate that the proposal cannot be co-located for technical/structural reasons.</p>	<p>As per Section 7 of this report, no suitable opportunities for co-location were identified in the area and it has been identified that the proposed Telstra site location is seen as the preferred site location. Colocation was investigated; however, the locations were either an existing Telstra site which is too far from the subject area to meet the capacity and coverage objectives of the proposal or the existing NBN tower which does not meet the capacity and coverage requirements of the project.</p>
<p><b>Location</b> 2.1 Carriers are encouraged to locate towers/monopoles within existing public utility corridors, at a height which is in keeping with the height and bulk of surrounding built form, away from public roads, to the rear of buildings and were the base of the tower/monopole is screened by established significant vegetation</p>	<p>The location of the facility has been strategically sited ensure minimal impact with the surrounding community and area. The facility is set back from the properties, northern boundary by 27 metres within an established rural property.</p> <p>The facility from the majority of locations along Oroton Road will be screened from existing vegetation flanking the roadside reserve. Furthermore, vegetation is proposed to be planted around the perimeter of the facility compound to screen the equipment shelter and lower portions of the facility.</p>
<p>2.2 Towers/monopoles should not be located within 200metres of land zoned Urban or Urban deferred in the Metropolitan Region Scheme (other than in special circumstances accepted by Council i.e. presence of a physical buffer between Telecommunications Infrastructure and residential area). Council may, however, consider the use of existing structures for the attachment of antennas and other equipment which does not require the construction of Telecommunications Infrastructure and does not adversely impact on the visual amenity of an area.</p>	<p>The proposed facility is to be located within a rural area, where the majority of uses can be identified as primary production. The site proposal is to be setback from the road and will be located off the northern boundary of the land in order to reduce any visual impact that facility may produce.</p>
<p>2.3 Telecommunications Infrastructure will not be supported where visual impact is incremental, due to the proximity of existing or approved Telecommunications Infrastructure.</p>	<p>The two closest telecommunications facilities are located both north and south of the proposed facilities, these being RFNSA No 6121004, 1.8km to the south and RFNSA No. 6121002 and 2.3km to the north east. Both these facilities are outside of Telstra's area of interest and therefore have been discounted for colocation.</p>
<p><b>Design 3.1</b> Telecommunications Infrastructure must be designed to have minimal impact on the streetscape and visual amenity by including the use of natural non-reflective colours and finishes.</p>	<p>The proposed facility will not be painted but will be kept dull grey to reduce reflection. The facility has been sited with a setback off Orton Road to reduce any visual amenity from passing vehicles or pedestrians that happen to pass.</p>
<p><b>Design 3.2</b>  All Telecommunications Infrastructure must be reasonably screened from view by vegetation.</p>	<p>The proposal will have reasonable and appropriate vegetation screening.</p>
<p><b>4. General Requirements</b> 4.1 All decommissioned mobile phone towers/monopoles shall be removed and the site</p>	<p>In the future should the site become redundant then all equipment will be removed from the site.</p>

<p>reinstated to its original condition at the proponent's cost.</p>	
<p><b>5. Planning Application Requirements</b>  <b>5.1 All planning applications for mobile phone towers/monopoles should be accompanied by the following:</b></p> <ol style="list-style-type: none"> <li>i. Location plans showing the location of the facility and any existing or known/planned facilities of the carrier and other carriers, within the Shire and adjoining local authorities.</li> <li>ii. Artist impressions depicting the proposed facility on the subject site.</li> <li>iii. Plans of the proposed mobile tower/monopole including the height, appearance, colour and location of equipment shelters.</li> <li>iv. A written submission detailing the following:             <ul style="list-style-type: none"> <li>o the need for the facility;</li> <li>o details of co-location investigations;</li> <li>o whether the applicant has notified other licensed carriers about the proposal and whether the other licensed carriers intend to co-locate on the proposed tower/monopole;</li> <li>o the intended service area of the facility including a map of service coverage;</li> <li>o whether excess space has been incorporated into the design and configuration of the structure of building for co-location and the suitability of that space for use by other licensed carriers;</li> </ul> </li> <li>v. Council may require the submission of documentation showing sight lines demonstrating the level of visibility of the facility as viewed from adjacent properties or streets and elevations of all proposed improvements on the site;</li> </ol>	<p>The planning application requirements are outlined within this report as well as attached, in summary the following has been attached for assessment</p> <ul style="list-style-type: none"> <li>• Full set of plans showing the location of the facility, colours and finishes as well as ancillary equipment and outbuildings.</li> <li>• A set of montages displaying elevation impressions of the site once built.</li> </ul>



## Shire of Serpentine-Jarrahdale Rural Strategy 2013

The overall purpose of the Rural Strategy is to preserve and enhance the Shire's rural character and its role as an important economic contributor to the Shire and broader region. Within the Shire's Rural Strategy three themes have emerged during review in 2017, these themes are the following; Theme 1- Protection of natural assets (Local Natural Areas), Theme 2-Protection of Rural Character, Theme-3 Facilitate productive rural areas. The Shire has further identified eighteen (18) universal objectives in which will be assessed against the proposal below.

Universal Objectives	Applicants response
1. Ensure that protection and enhancement of biodiversity assets in the Shire is considered early in the planning process.	Telstra has undertaken a precautionary approach that takes into account environmental assets prior to undertaking the planning process.
2. Maintain and enhance the quality and quantity of remnant vegetation throughout the Shire.	The proposal will not have any adverse impact on any remnant vegetation within the Byford area.
3. Protect the integrity of Resource enhancement and Conservation Category wetland throughout the Shire from inappropriate land use.	The proposal will not have any adverse impact on any conservation area or wetland as the footprint of the area is 99sqm. Furthermore, the land use has an extremely small impact on the environment in terms of land area and human interaction with the facility.
4. Minimise offsite nutrient loading through appropriate land management and drainage considerations	Appropriate land management and drainage considerations will be undertaken to ensure minimal offsite nutrient loading occurs. This will occur due to the small amount of excavation that will occur with the construction of the proposed facility.
5. Recognise that a large proportion of the Shire's rural areas are classified as Multiple Use palusplain and that there may be opportunities for bona-fide rural activity within these areas.	A telecommunications facility developed and operational in Byford will assist in further opportunities for bona-fide rural activities and businesses.
6. Consider sustainable and efficient groundwater use, allocation and alternative water sources as an integral component of the planning process.	The telecommunications facility that will not have an effect on ground water use or allocation.
7. Prevent the worsening of land and water quality as a result of development, particularly on the palusplain	The proposed telecommunications facility will not have a worsening effect on the land and water quality of the palusplain, as the area of the land facility is quite small.
8. Maintain the 'nodal' pattern of urban development and urban villages in the Shire, interspersed with rural wedges. Specifically maintain a distinct rural wedge between Serpentine and existing/proposed urban areas to the north.	The proposed facility will not have any effect on the nodal pattern of development with regards to urban villages within the Shire.
9. Facilitate an appropriate form of rural living development in appropriate locations	The proposed facility complements rural living development.
10. Protect the landscape integrity of the scarp	The facility is not considered to significantly impact the integrity of the surrounding landscape. Refer to the photomontages provided as part of the application to Council.
11. Recognise landscape as a legitimate issue for consideration within the planning and development process.	The proposed facility has been deliberately sited so as to not impact on the landscape of the area.



12. Subject to confirmation in the Urban Growth and Activity Centres strategies, limit the identification of new urban nodes within the Shire for the lifetime of this strategy.	Not applicable, proposal is for a Telecommunications Facility.
13. Consolidate medium-long term urban growth within the already defined areas of Byford and Mundijong-Whitby	The proposed facility will complement both medium- and long-term urban growth with the Mundijong-Whitby areas.
14. Recognise the legitimacy of a broad economic base within the Shire's rural areas that does not focus solely on broad-acre agriculture	The proposed telecommunications facility will complement and assist the Shire's broad economic base within rural areas.
15. Recognise and facilitate the on-going economic development of the Shire's rural industries/activities as a mechanism to meet the objectives of the natural assets and rural atmosphere objectives (identified above)	The proposed telecommunications facility will complement and assist in the development of the Shire's rural industries and activities
16. Promote Agri-and rural-tourism within the Shire	The proposed telecommunications facility will complement the promotion of agricultural and rural tourism within the Shire by providing fast and efficient internet and telecommunications to both businesses and visitors to the Shire.
17. Recognise the importance of the best practice environmentally managed extraction of Basic Raw Materials within the Shire.	Not applicable, proposal is for a Telecommunications Facility.
18. Promote and encourage alternative agricultural land uses (provided they do not contribute to land degradation)	The proposed telecommunications facility will help in promoting and encouraging alternative agricultural land uses through providing fast and efficient internet and telecommunications.

## 11.0 General Provisions

This proposal is for the establishment of a Telstra Mobile Base Station Facility in the Byford/Oldbury locality.

Telstra considers that the proposal is appropriate for the locality given the 'Rural' zoning of the proposed site and the nature of existing and anticipated uses of the surrounding land.

Environmental considerations such as visual impact, heritage, flora and fauna, traffic, flooding, bushfire, social and economic aspects, health and safety have been discussed within the below sub sections.

### 11.1 Visual Impacts

The site has been identified as being located within the 'Rural' zone. In this regard, the detailed siting and design of the proposed facility has been taken this into consideration in conjunction with the aims of the Shire's *Local Planning Scheme No. 2*.

Telstra has selected a site and location that seeks to minimise any perceived negative impacts on the visual amenity of the area. The proposed subject site maintains suitable separation distance to surrounding rural and residential areas and takes advantage of the shielding provided by nearby mature vegetation which limits the structure's visibility from neighbouring properties.

The site selection carefully considered environmental and visual constraints, existing and future land use characteristics, the orderly planning of the area and the design of the facility. On balance, it is considered that the location and height of the facility ensure optimal service provision to the area whilst minimising any perceived visual impact. Moreover, as previously mentioned the site will also provide other carriers with the opportunity to co-locate their infrastructure in the future.



## 11.2 Heritage

In order to determine any possible natural or cultural values of state or national significance associated with the site a search was conducted through the relevant Heritage Registers.

No heritage sites, including Aboriginal heritage sites, of significance were identified within the subject land holding or within close proximity.

## 11.3 Flora and Fauna

In order to determine any possible natural Flora and Fauna significance associated with the site, a search was conducted through the relevant environmental searches.

Searches identified the potential of 21 threatened ecological community and 9 migratory species of Flora and Fauna significance located in the vicinity of the proposed site. See **Appendix F** – Environment Analysis Report for further information.

The site is not located in an area of environmental significance as defined by The *Telecommunications (Low-Impact Facilities) Determination 2018*.

## 11.4 Traffic

Mobile phone base stations are not a significant generator of pedestrian or vehicular traffic.

The site will be visited on a quarterly basis throughout the year for maintenance purposes.

During the construction phase various vehicles will be used to deliver equipment and construct the Telstra Mobile Base Station Facility. Any traffic impacts associated with construction and establishment will be of a short-term duration (i.e. approximately five weeks over non-consecutive periods) and are not anticipated to adversely impact on the surrounding road network.

Adequate parking will be available on site for these vehicles and these movements would not impact the local traffic.

Traffic from this construction would only occur from the hours of 7am to 6pm. If a road closure is required for the erection and installation of equipment, the appropriate approvals will be obtained from the Department of Transport (DoT).

The mobile base station facility is unmanned would require maintenance checks approximately 3-4 times per year as required. Routine maintenance would involve one vehicle per visit and parking would be available close to the proposed site for this purpose.

## 11.5 Access

Access to the proposed site will be through a proposed crossover off Orton Road (Refer to **Appendix B** – Proposal Plans (S1) for more information)

The proposed site access is considered to be appropriate given the Telstra facility will not be a significant generator of traffic. Once operational, the facility will require maintenance visits approximately 3-4 times per year as required but will remain unattended at all other times. As the facility generates minimal visits per year it is considered that traffic interference will be negligible.

During the construction phase various vehicles will be used to deliver equipment and construct the Telstra Mobile Base Station Facility. Any traffic impacts associated with construction and establishment will be of a short-term duration (i.e. approximately five weeks over non-consecutive periods) and are not anticipated to adversely impact on the surrounding road network. Adequate parking would be available in the vicinity

for vehicles used during construction and these movements would not impact local traffic. In the unlikely event that road closure is required Telstra will apply to the relevant authorities for permission.

## 11.6 Utilities

The proposal will connect to the existing power supply nearby. An application will be made to the local utility company confirming route and availability of power supply for this site. The proposed site does not require any additional permits for the connection of a sewer/roadway.

Furthermore, the proposal incorporates very minimal hard surfaces and therefore will generate insignificant stormwater runoff from the site.

## 11.7 Construction

The construction of the mobile base station will take approximately five weeks over non-consecutive periods, subject to weather.

Noise and vibration emissions associated with the Telstra Mobile Base Station Facility will be limited to the construction phase. Noise generated during the construction phase will be of short duration and will be in accordance with the standards outlined in the *Environmental Protection (Noise) Regulations 1997*. Construction works will only occur between the hours of 7am and 6pm.

There will be some low-level noise from the ongoing operation of air conditioning equipment associated with the equipment shelter once it is installed. Noise emanating from the air conditioning equipment is at a comparable level to a domestic air conditioning installation and will generally accord with the background noise levels prescribed by *Australian Standard AS1055*.

The proposed site is appropriately setback from residential properties so that the noise related impacts will be negligible.

## 11.8 Bushfire

The specific site location is identified as not being in a Bush Fire Prone Area by the Fire and Emergency Services Commissioner (See **Figure 6**).

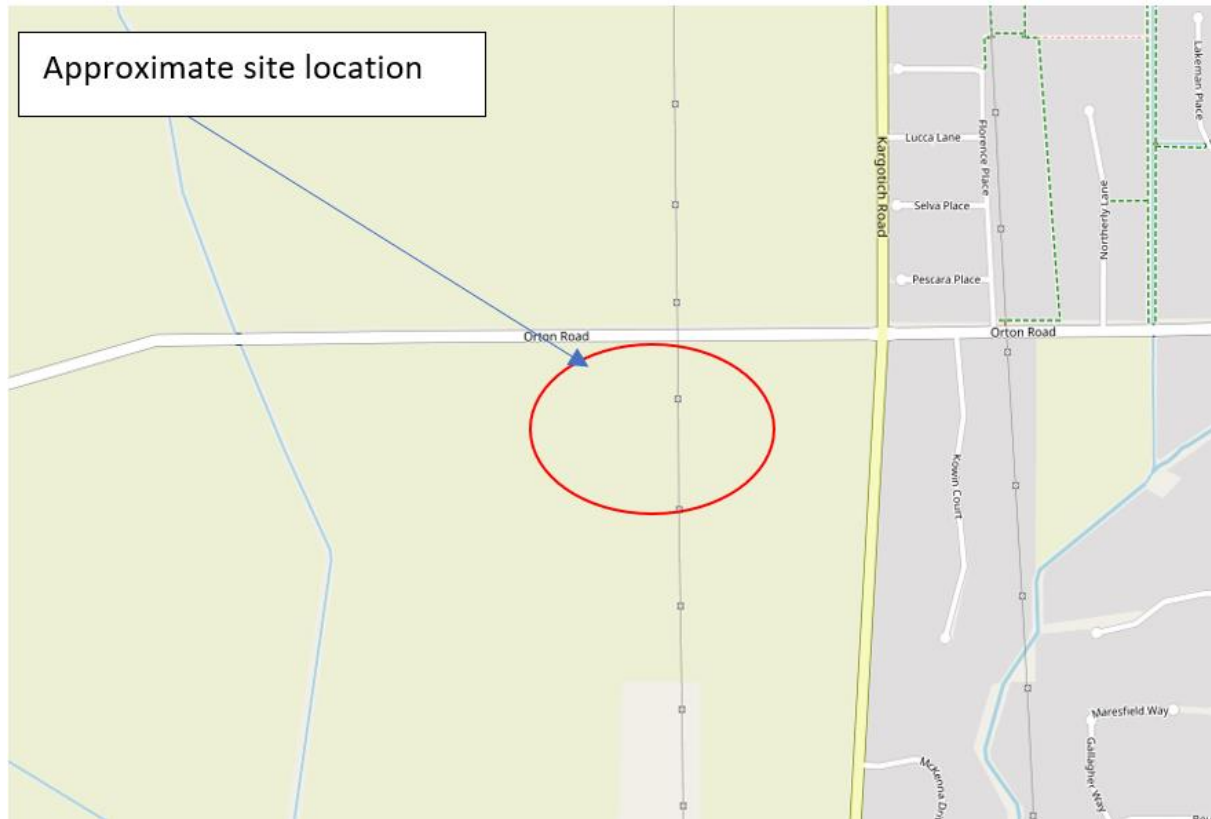

**Figure 6 – Bushfire Prone Areas Mapping (Source DFES Slip Mapping)**

Natural disasters, including the continuing threat of bushfires, have served to highlight the critical importance of effective telecommunications. Previous bushfire incident reviews have demonstrated effective telecommunications networks are essential for disaster response management, allowing emergency services providers to be alerted to medical or fire emergencies.

In its *Communications Report 2014-2015* the Australian Communications and Media Authority reported that in 2014 -15, 66.9% of calls to the 000 emergency number were made from mobile phones. Therefore, in addition to day-to-day personal and business applications, effective telecommunications networks can be the difference between life and death in disaster situations.

The entirety of the facility will be earthed in accordance with the Australian Standard. Earthing draws any lightning strike underground away from combustible material. It is submitted that contrary to being a risk factor for fires, the site in this case could reduce the risk of lightning strike causing fires, by attracting the strike and earthing it underground.

The *State Planning Policy 3.7* provides the foundation for land use planning to address bushfire risk management in Western Australia. Notwithstanding the Department of Planning updated [Planning Bulletin 111/2016](#) to clarify that for telecommunications infrastructure, *SPP 3.7* should be applied pragmatically.

The Planning Bulletin states:

*“Exemptions from the requirements of SPP 3.7 and the deemed provisions should be applied pragmatically by the decision maker. If the proposal does not result in the intensification of development (or land use), does not result in an increase of residents or employees; or does not involve the occupation of employees on site for any considerable amount of time, then there may not be any practicable reason to require a BAL Assessment. Exemptions may apply to infrastructure including roads, telecommunications and dams; and to rural activities, including piggeries and chicken farms which do not involve employees on site for a considerable amount of time.”*

With respect to the above, Visionstream on behalf of Telstra believes that all necessary design measures have been undertaken to ensure the facility does not increase or affect the bushfire risk to the area.

## 11.9 Health and Safety

Telstra acknowledges some people are genuinely concerned about the possible health effects of electromagnetic energy (EME) from mobile phone base stations and is committed to addressing these concerns responsibly.

Telstra, along with the other mobile phone carriers, must strictly adhere to Commonwealth Legislation and regulations regarding mobile phone facilities and equipment administered by the Australian Communications and Media Authority (ACMA).

In 2003 the ACMA adopted a technical standard for continuous exposure of the general public to RF EME from mobile base stations. The standard, known as the *Radiocommunications (Electromagnetic Radiation – Human Exposure) Standard 2003*, was prepared by the Australian Radiation Protection and Nuclear Safety Agency (ARPANSA) and is the same as that recommended by ICNIRP (International Commission for Non- Ionising Radiation Protection), an agency associated with the World Health Organisation (WHO). Mobile carriers must comply with the Australian Standard on exposure to EME set by the ACMA.

The Standard operates by placing a limit on the strength of the signal (or RF EME) that Telstra can transmit to and from any network base station. The general public health standard is not based on distance limitations or the creation of “buffer zones”. The environmental standard restricts the signal strength to a level low enough to protect everyone at all times. It has a significant safety margin, or precautionary approach, built into it.

In order to demonstrate compliance with the standard, the ARPANSA created a prediction report using a standard methodology to analyse the maximum potential impact of any new telecommunications facility. Carriers are obliged to undertake this analysis for each new facility and make it publicly available.

Importantly, the ARPANSA-created compliance report demonstrates the maximum signal strength of a proposed facility, assuming that it is handling the maximum number of users 24-hours a day.

In this way, the ARPANSA requires network carriers to demonstrate the greatest possible impact that a new telecommunications facility could have on the environment to give the community greater peace of mind. In reality, base stations are designed to operate at the lowest possible power level to accommodate only the number of customers using the facility at any one time. This design function is called “adaptive power control” and ensures that the base station operates at minimum, not maximum, power levels at all times.

Using the ARPANSA standard methodology, Telstra is required to complete and make available an EME report which predicts the maximum environmental EME level the facility will emit. Telstra has undertaken a compliance report that predicts the maximum levels of radiofrequency EME from the proposed installation at 928 Orton Road, Oldbury to be **2.12%** of the public exposure limit. The maximum environmental EME level predicted from this proposed facility is substantially within the allowable limit under the ARPANSA standard.

### **Refer to the EME Report attached at Appendix C.**

Telstra relies on the expert advice of national and international health authorities such as the Australian Radiation Protection and Nuclear Safety Agency (ARPANSA) and the World Health Organisation (WHO) for overall assessments of health and safety impacts.

The WHO advises that all expert reviews on the health effects of exposure to radiofrequency fields have concluded that no adverse health effects have been established from exposure to radiofrequency fields at levels below the international safety guidelines that have been adopted in Australia.

Telstra has strict procedures in place to ensure its mobile phones and base stations comply with these guidelines. Compliance with all applicable EME standards is part of Telstra’s responsible approach to EME and mobile phone technology.

## 11.10 Erosion, Sediment Control and Waste Management

All erosion and sediment control mitigation measures will be detailed in construction plans and will comply with the *Building Code of Australia* and Local Council Standards. On completion of the installation, the site will be restored and reinstated to an appropriate standard. No waste which requires collection or disposal will be generated by the operation of the facility.

## 11.11 Social and Economic Impact

Reliable mobile phone coverage is important to ensure the economic growth of communities. It is not expected to have any adverse social or economic impacts as a result of the development. Indeed, it is anticipated that there would be positive impacts because of the mobile telephone coverage, and the proposed facility could also be utilised in the event of an emergency with reference to mobile phone and internet use.

The proposed development is essential to enable Carriers to remain competitive and increase the choice of mobile telephone services to consumers. Additional competition in the market will have economic benefits for individual consumers and the community as a whole. The development is consistent with the objectives of the *Telecommunications Act 1997*, namely:

- To promote “the efficiency and international competitiveness of the Australian telecommunications industry” (s.3 (1)); and
- To ensure that telecommunications services “are supplied as efficiently and economically as practicable” (s.3 (2) (a) (ii).

## 12.0 Conclusion

There is strong State policy support for telecommunications facilities if, when balancing improved telecommunications services with environmental impacts; including for example, visual impact and flood or fire hazard, a particular proposal provides a net community benefit.

The proposed works would provide the community with reliable and enhanced 4G and 5G access, particularly in building coverage, which in turn supports the various rural, residential and tourist industries in the region and form part of a wider plan to ensure reliable and accessible coverage during emergency situations such as in the event of bush fires.

The proposed telecommunications facility will form an integral component in Telstra’s national 4G and 5G network. This service brings higher speeds and extra coverage to a range of communities across the nation. 4GX will include services provided over Telstra’s new 700MHz spectrum and deliver higher typical mobile speeds on compatible devices, allowing more Australians to experience more reliable connections and ultra-fast mobile internet. Moreover, this additional site will also help to make the Byford region 5G ready.

Telstra has undertaken an assessment of the relevant matters as required by the *Telecommunications Act 1997*, State Legislation and the Shire of Serpentine Jarrahdale *Local Planning Scheme No. 2*. The proposal is considered appropriate in light of the relevant legislative, environmental, technical, radio coverage/capacity and public safety requirements.

The proposed facility is considered appropriate for the subject site for the following reasons:

- The facility will provide reliable mobile phone service to the growing Byford area. It will deliver mobile coverage and capacity to regional and remote communities who will be able to access fast mobile voice and data services. The improved service is increasing access to new technologies for key regional sectors and communities, which rely on a fast, reliable and affordable mobile network.
- Public views to the facility are limited by the rural nature of the land and the presence of mature vegetation

- The proposal is consistent with the relevant provisions of the *Shire of Serpentine Jarrahdale Planning Scheme No. 2*.
- The proposal will improve Telstra 4G and 5G communications services to the area, including voice calls, video calling and Wireless Broadband – a high speed wireless internet service via the 4G and particularly the 5G phone network.
- The proposed facility is appropriately located on land that is rural in nature, providing good separation from residential properties.
- Overall it is considered that the proposed facility is acceptable and will not cause a considerable loss of visual amenity to the surrounding area due to the facility's design and presence of mature vegetation present on the subject property. It is submitted that a reasonable balance has been struck between the technical requirements for a new facility in this area, the need to deliver an optimum level of service based on the capacity and level of coverage delivered by a facility of this height and the need to minimise visual and other environmental impacts.
- The proposed installation will provide possible opportunities for future co-location on the monopole by other Carriers.
- Emissions from the proposed facility will be significantly below the Australian Radiation Protection and Nuclear Safety Agency standards adopted by the Australian Communications and Media Authority.

The assessment of the proposal demonstrates that the proposal represents sound and proper town planning and it is respectfully requested that consent is granted for this development application.

Should Council have any further queries regarding the subject application, please do not hesitate to contact the nominated representative outlined within this document.

**Appendix A – Certificate of Title**



## **Appendix B – Plans of the Proposal**



Plot date: 24 March 2020 - 9:12 AM  
Telstra Networks Wireless Program Delivery Template - 017866P02 Issue 12 11/04/2016

**NOTE:**  
1. HAUL 12F TOTAL DIST OF 689.0m IN EXISTING CONDUIT & 95.0m IN NEW (INC LEAD-IN CONDUIT).

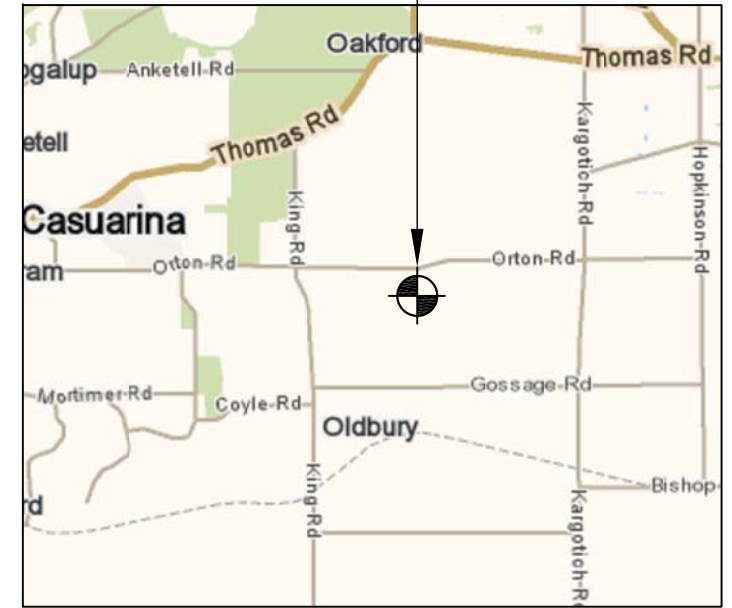

Copyright © Whereis® Registered Trademark of Sensis Pty Ltd.

**LOCALITY PLAN**  
NOT TO SCALE

**SERVICES LEGEND**

- T — T — T — OPTICAL FIBRE ABOVE GROUND
- - - T - - - T - - - OPTICAL FIBRE BELOW GROUND
- E — E — ABOVE GROUND ELECTRICAL SUPPLY
- - - E - - - E - - - BELOW GROUND ELECTRICAL SUPPLY

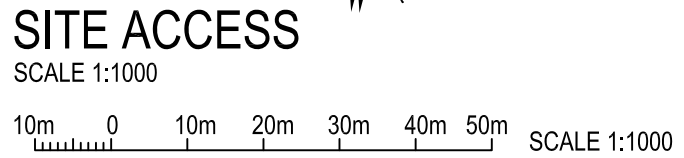
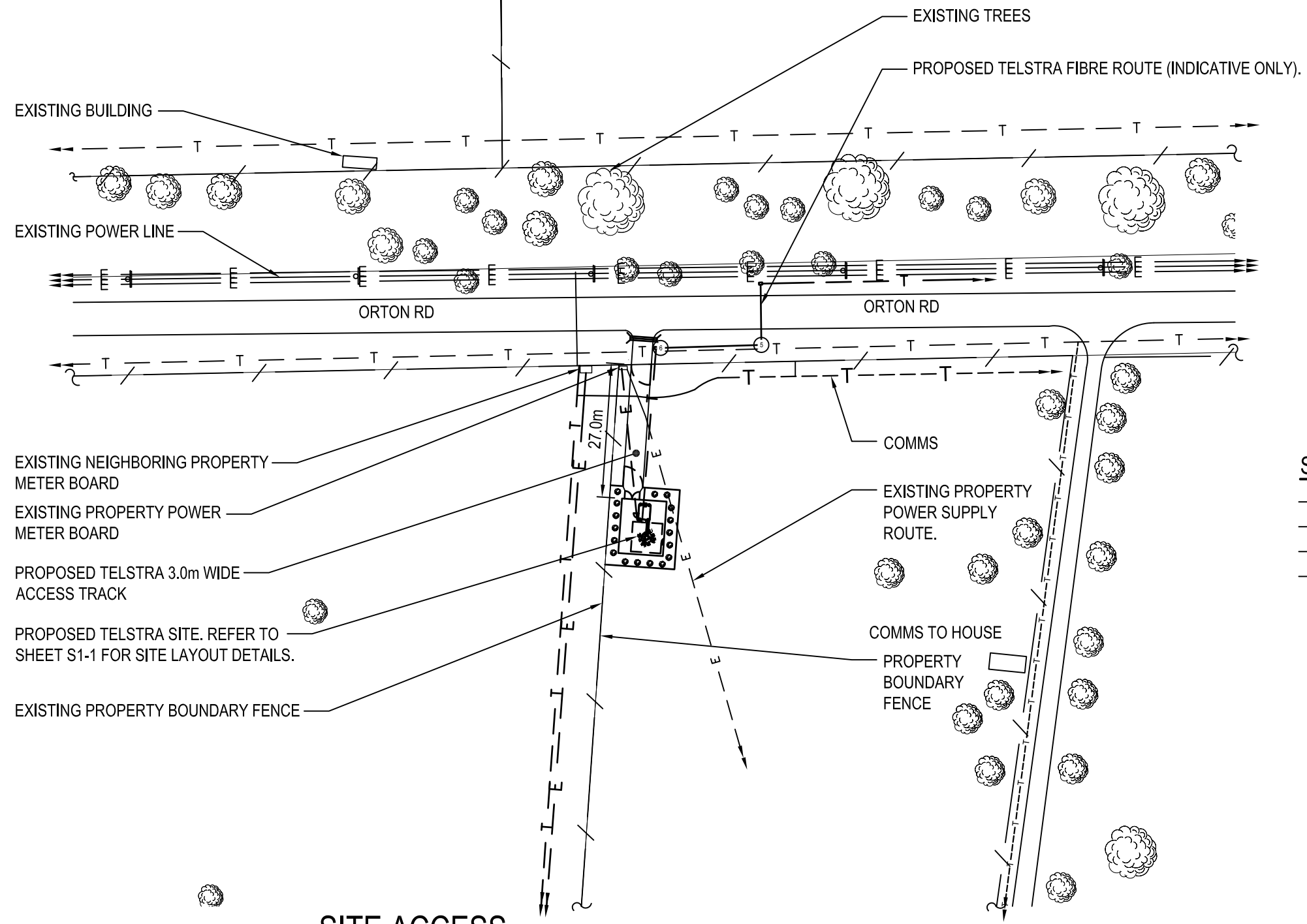

PROPERTY DESCRIPTION		SITE STRUCTURE CO-ORDINATES (GDA94)	
LOT 233 DP 152813 LOCAL GOVERNMENT AREA (LGA): SHIRE OF SERPENTINE-JARRAHDALE		GPS READING ACCURACY: ±10m CENTRE OF MONOPOLE	
LATITUDE	-32.23637° (GDA94)	LONGITUDE	115.94485° (GDA94)

**COMPLIANCE BOX**  
COMPLETED AS PER DESIGN   
ALTERATIONS IN RED   
NAME (PRINT) \_\_\_\_\_  
SIGNATURE \_\_\_\_\_ DATE \_\_\_\_\_



TO BE READ IN CONJUNCTION WITH SHEETS S1-1, S1-2, S3 & S3-1.

ORDER	DRAWN	CHKD	AMENDMENT	EXAM	APPD	DATE	ISS
WA07145.01	RH	AH	PRELIMINARY - 30084149W0062 VPL - LTE700/LTE1800/LTE2100/NR850	SZ	RO	27.02.20	1

**PRELIMINARY**

**Telstra**

**MOBILE NETWORK SITE 323359**  
**BYFORD WEST**  
SITE ACCESS AND LOCALITY PLAN  
928 ORTON RD, OLDBURY, WA 6121

DWG NO.	<b>W109496</b>	SHT NO.	S1
---------	----------------	---------	----

Plot date: 24 March 2020 - 9:13 AM

Telstra Networks Wireless Program Delivery Template - 017866P02 Issue 12 11/04/2016

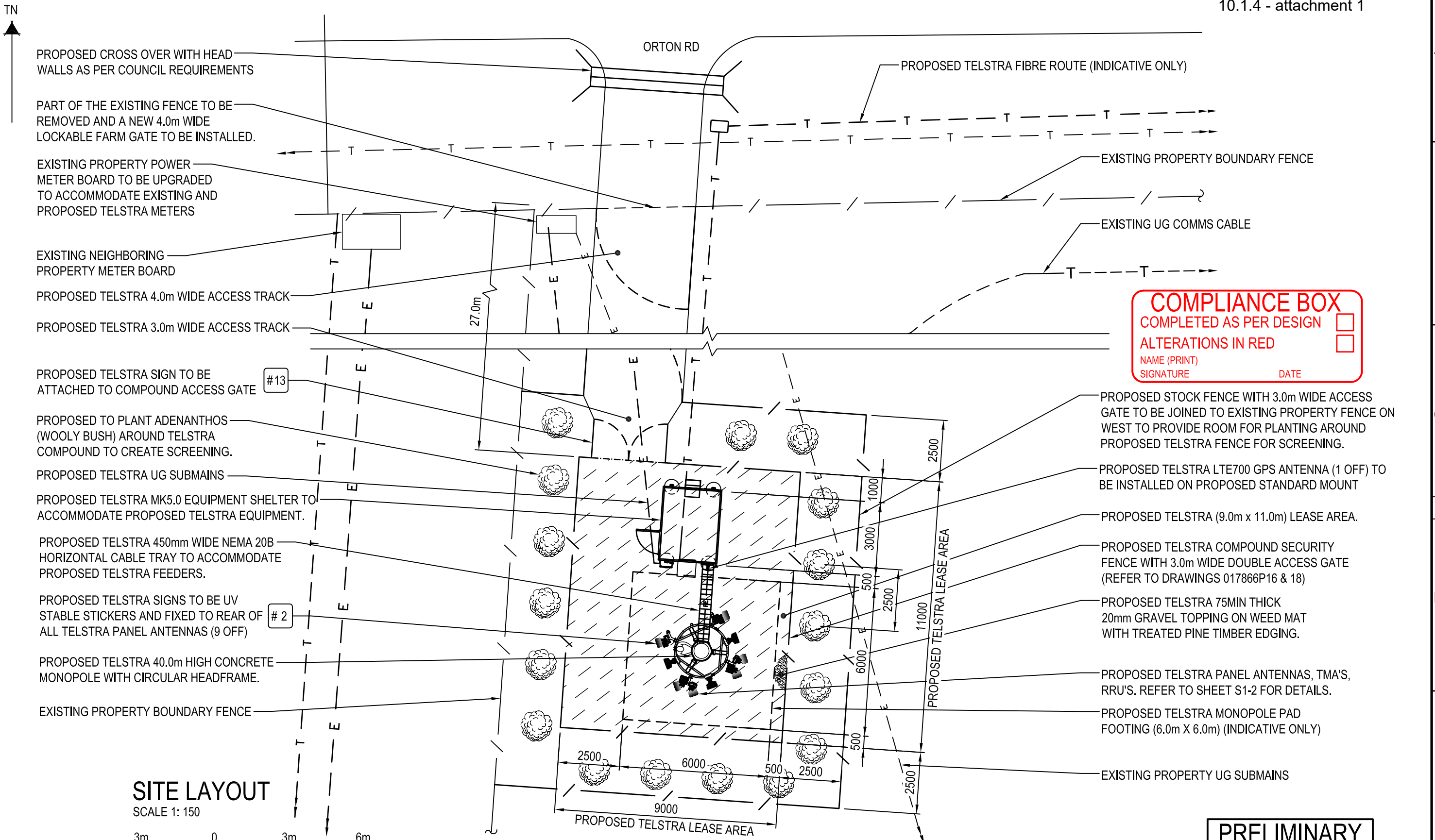

**COMPLIANCE BOX**  
 COMPLETED AS PER DESIGN   
 ALTERATIONS IN RED   
 NAME (PRINT) \_\_\_\_\_  
 SIGNATURE \_\_\_\_\_ DATE \_\_\_\_\_

**SITE LAYOUT**  
SCALE 1: 150

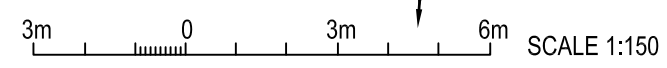

**NOTES :**

1. ALL FEEDERS ACCESS POINTS ON THE STRUCTURE MUST BE BIRD PROOFED AS PER EXTERNAL PLANT POLICY 003615.
2. FOR EME SIGNS NOTED AS #X REFER TO 005486 DOCUMENTS FOR DETAILS.
3. ALL DIMENSIONS ARE IN MILLIMETRES UNLESS OTHERWISE STATED.
4.  PROPOSED TELSTRA LEASE AREA.
5. PLANTING TO BE DONE DURING LATE AUTUMN/ EARLY WINTER TO MINIMISE MAINTENANCE PERIOD
6. PLANT TO BE LOCAL NATIVE PLANT AND TO REACH 4.0m HEIGHT MAX WHEN MATURED.
7. HAUL 12F TOTAL DIST OF 689.0M IN EXISTING CONDUIT & 95.0M IN NEW (INC LEAD-IN CONDUIT).



TO BE READ IN CONJUNCTION WITH SHEETS S1, S1-2, S3 & S3-1.

ORDER	DRAWN	CHKD	AMENDMENT	EXAM	APPD	DATE	ISS
WAO7145.01	RH	AH	PRELIMINARY - 30084149W0062 VPL - LTE700/LTE1800/LTE2100/NR850	SZ	RO	27.02.20	1

**PRELIMINARY**

**Telstra**  
 MOBILE NETWORK SITE 323359  
 BYFORD WEST  
 SITE LAYOUT  
 928 ORTON RD, OLDBURY, WA 6121

DWG NO.	<b>W109496</b>	SHT NO.	S1-1
---------	----------------	---------	------

Plot date: 24 March 2020 - 8:23 AM  
Telstra Networks Wireless Program Delivery Template - 017866P02 Issue 12 11/04/2016

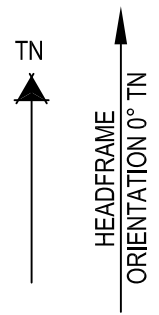

PROPOSED TELSTRA CIRCULAR HEADFRAME TO ACCOMMODATE PROPOSED TELSTRA ANTENNA, TMA'S & RRU'S. REFER TO DRAWING 017866P170 SHEETS 7 & 8.

PROPOSED TELSTRA CLIMBING PEG

PROPOSED TELSTRA INTERFACE JUNCTION BOXES (3 OFF) TO BE ATTACHED TO PROPOSED ANTENNAS MOUNTS (A7, A8 & A9)

PROPOSED TELSTRA LTE1800/LTE2100 RADIO 4443 (B3 & B1) (3 OFF) TO BE ATTACHED TO PROPOSED MOUNTS BEHIND PANEL ANTENNAS (A1, A3 & A5)

PROPOSED TELSTRA LTE700 / LTE1800 / LTE2100 / NR850 PANEL ANTENNAS (3 OFF A1, A3 & A5) TO BE INSTALLED ON PROPOSED MOUNTS ON PROPOSED CIRCULAR HEADFRAME.

PROPOSED TELSTRA LTE700 TMA'S (6 OFF) ATTACHED TO PROPOSED MOUNT BEHIND PANEL ANTENNAS (A1, A2, A3, A4, A5 & A6).

PROPOSED TELSTRA 40.0m HIGH MONOPOLE

PROPOSED TELSTRA LTE2600 RADIO 4415 (B7) (3 OFF) TO BE ATTACHED TO PROPOSED MOUNTS BEHIND PANEL ANTENNAS (A2, A4 & A6)

PROPOSED TELSTRA LTE700 / LTE2600 PANEL ANTENNAS (3 OFF A2, A4 & A6) TO BE INSTALLED ON PROPOSED MOUNTS ON PROPOSED CIRCULAR HEADFRAME

PROPOSED TELSTRA NR3600 PANEL ANTENNAS (3 OFF A7, A8 & A9) TO BE INSTALLED ON PROPOSED MOUNTS ON PROPOSED CIRCULAR HEADFRAME

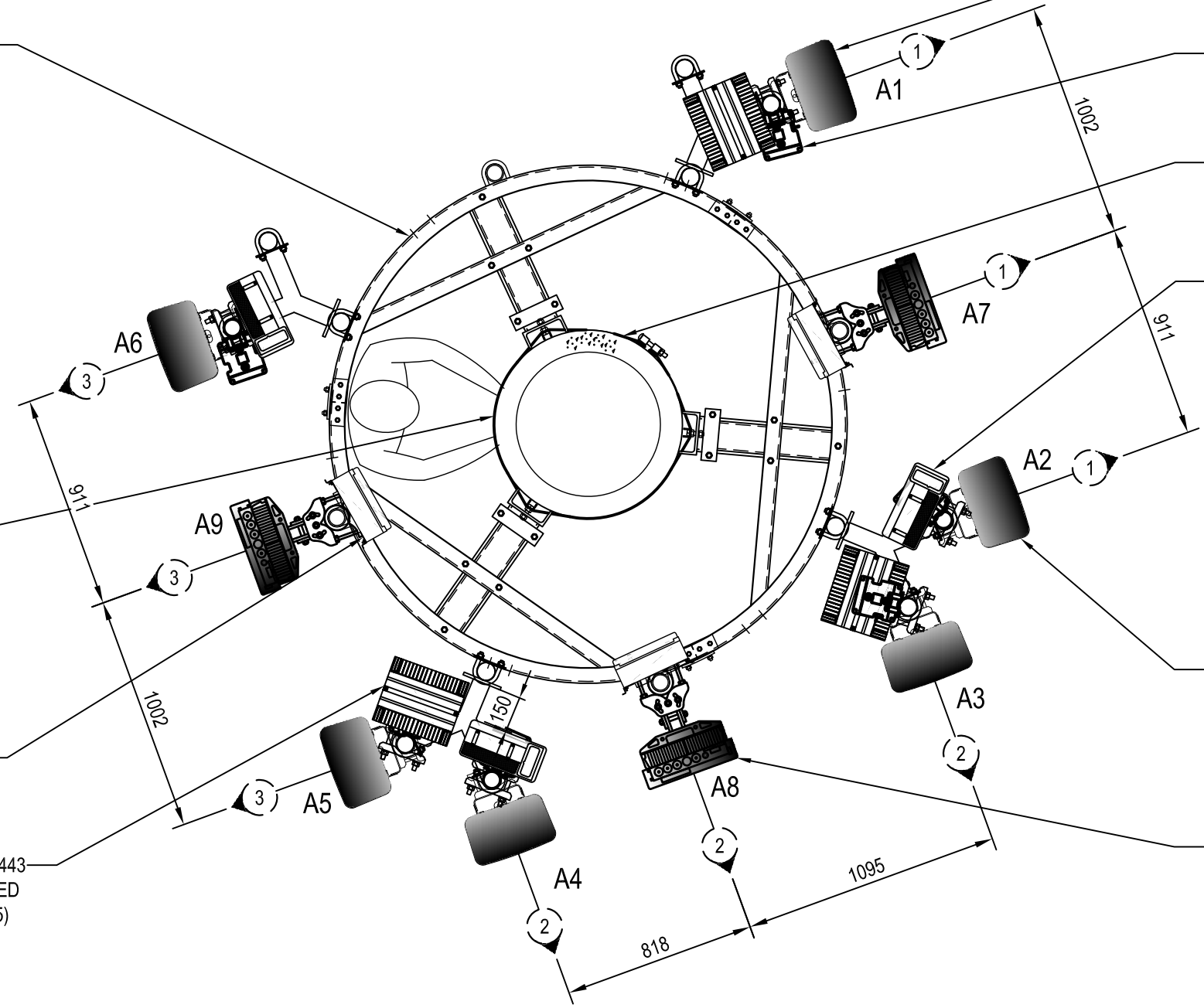

ANTENNA LAYOUT AT EL 39.3m AND RRU LAYOUT AT EL 40.2m

SCALE 1:25  
250 0 250 500 750 1000 1250 SCALE 1:25

**PRELIMINARY**

TO BE READ IN CONJUNCTION WITH SHEETS S1, S1-1, S3 & S3-1.

ORDER	DRAWN	CHKD	AMENDMENT	EXAM	APPD	DATE	ISS
WA07145.01	RH	AH	PRELIMINARY - 30084149W0062 VPL - LTE700/LTE1800/LTE2100/NR850	SZ	RO	27.02.20	1

**Telstra**

MOBILE NETWORK SITE 323359  
BYFORD WEST  
ANTENNA LAYOUT  
928 ORTON RD, OLDBURY, WA 6121

**COMPLIANCE BOX**  
COMPLETED AS PER DESIGN   
ALTERATIONS IN RED   
NAME (PRINT) \_\_\_\_\_  
SIGNATURE \_\_\_\_\_ DATE \_\_\_\_\_



© Telstra Corporation Limited ABN 33 051 775 556 All rights reserved.

Ordinary Council Meeting - 16 November 2020

DWG NO. **W109496** SHT NO. S1-2  
Cad file: W109496\_PD.dwg

P:\01\24 March 2020 - 624.AM  
 Telstra Networks Wireless Program Delivery Template - 017866P02 issue 12 11/04/2016

**10.1.4 - attachment 1**

PROPOSED TELSTRA LTE2600 RADIO 4415 (B7) (3 OFF) TO BE ATTACHED TO PROPOSED MOUNTS BEHIND PANEL ANTENNAS (A2, A4 & A6)

PROPOSED TELSTRA INTERFACE JUNCTION BOXES (3 OFF) TO BE ATTACHED TO PROPOSED ANTENNA MOUNTS (A7, A8 & A9)

PROPOSED TELSTRA LTE700 / LTE2600 PANEL ANTENNAS (3 OFF A2, A4 & A6) TO BE INSTALLED ON PROPOSED MOUNTS ON PROPOSED CIRCULAR HEADFRAME

▽ E.L. 40.65m RL 56.65m A.H.D.  
OVERALL HEIGHT

PROPOSED TELSTRA LTE1800/LTE2100 RADIO 4443 (B3 & B1) (3 OFF) TO BE ATTACHED TO PROPOSED MOUNTS BEHIND PANEL ANTENNAS (A1, A3 & A5)

▽ E.L. 40.2m RL 56.2m A.H.D.  
C/L PROPOSED TELSTRA LTE2600 RADIO 4415 (B7) (3 OFF)  
C/L PROPOSED TELSTRA INTERFACE JUNCTION BOXES (3 OFF)  
C/L PROPOSED TELSTRA LTE1800/LTE2100 RADIO 4443 (B3/B1) (3 OFF)

PROPOSED TELSTRA LTE700 TMA'S (6 OFF) ATTACHED TO PROPOSED MOUNT BEHIND PANEL ANTENNAS (A1, A2, A3, A4, A5 & A6).

▽ E.L. 40.0m RL 56.0m A.H.D.  
TOP OF MONOPOLE

PROPOSED TELSTRA NR3600 PANEL ANTENNAS (3 OFF A7, A8 & A9) TO BE INSTALLED ON PROPOSED MOUNTS ON PROPOSED CIRCULAR HEADFRAME

▽ E.L. 39.3m RL 55.3m A.H.D.  
PROPOSED TELSTRA LTE700 / LTE1800 / LTE2100 / NR850 PANEL ANTENNAS (3 OFF A1, A3 & A5)  
C/L PROPOSED TELSTRA LTE700 / LTE2600 PANEL ANTENNAS (3 OFF A2, A4 & A6)  
C/L PROPOSED TELSTRA NR3600 PANEL ANTENNAS (3 OFF, A7, A8 & A9)  
C/L OF PROPOSED TELSTRA LTE700 TMA'S (6 OFF)

PROPOSED TELSTRA LTE700 / LTE1800 / LTE2100 / NR850 PANEL ANTENNAS (3 OFF A1, A3 & A5) TO BE INSTALLED ON PROPOSED MOUNTS ON PROPOSED CIRCULAR HEADFRAME

# 2 PROPOSED SIGNS TO BE UV STABLE STICKERS AND FIXED TO REAR OF ALL TELSTRA PANEL ANTENNAS (9 OFF)

PROPOSED TELSTRA CIRCULAR HEADFRAME TO ACCOMMODATE PROPOSED TELSTRA ANTENNAS, TMA'S & RRU'S. REFER TO DWG. 017866P170 SHEETS 7 & 8 FOR DETAILS.

PROPOSED TELSTRA 40.0m HIGH CONCRETE MONOPOLE WITH CIRCULAR HEADFRAME.

**NOTES :**

1. ALL FEEDERS ACCESS POINTS ON THE STRUCTURE MUST BE BIRD PROOFED AS PER EXTERNAL PLANT POLICY 003615.
2. FOR EME SIGNS NOTED AS #X REFER TO 005486 DOCUMENTS FOR DETAILS.
3. ALL DIMENSIONS ARE IN MILLIMETRES UNLESS OTHERWISE STATED.
4. PLANT TO BE LOCAL NATIVE PLANT AND TO REACH 4.0m HEIGHT MAX WHEN MATURED.
5. HAUL 12F TOTAL DIST OF 689.0M IN EXISTING CONDUIT& 95.0M IN NEW (INC LEAD-IN CONDUIT).
6. PROPOSED TO PLANT ADENANTHOS NOT SHOWN IN FRONT SITE FOR CLARITY.

PROPOSED TELSTRA 450mm WIDE NEMA 20B HORIZONTAL CABLE TRAY

PROPOSED TELSTRA LTE700 GPS ANTENNA (1 OFF BEHIND) ON PROPOSED STANDARD MOUNT

PROPOSED TELSTRA MK5.0 EQUIPMENT SHELTER TO ACCOMMODATE PROPOSED TELSTRA EQUIPMENT.

EXISTING PROPERTY BOUNDARY FENCE.

PROPOSED TELSTRA COMPOUND SECURITY FENCE WITH 3.0m WIDE DOUBLE ACCESS GATE (REFER TO DRAWINGS 017866P16 & 18)

PROPOSED TO PLANT ADENANTHOS- (WOOLY BUSH) AROUND TELSTRA COMPOUND TO CREATE SCREENING.

PROPOSED TELSTRA SIGN TO BE ATTACHED TO COMPOUND ACCESS GATE #13

PROPOSED TELSTRA U/G POWER LINE

▽ E.L. 00.0m RL 16.0m A.H.D.  
GROUND LEVEL

**SOUTH ELEVATION**

SCALE 1:150

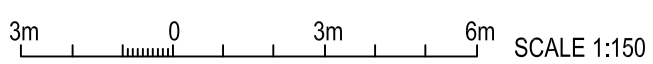

COMPLIANCE BOX

COMPLETED AS PER DESIGN

ALTERATIONS IN RED

NAME (PRINT) \_\_\_\_\_

SIGNATURE \_\_\_\_\_ DATE \_\_\_\_\_

**PRELIMINARY**

TO BE READ IN CONJUNCTION WITH SHEETS S1, S1-1, S1-2 & S3-1.

ORDER	DRAWN	CHKD	AMENDMENT	EXAM	APPD	DATE	ISS
WA07145.01	RH	AH	PRELIMINARY - 30084149W0062 VPL - LTE700/LTE1800/LTE2100/NR850	SZ	RO	27.02.20	1

Telstra

MOBILE NETWORK SITE 323359  
BYFORD WEST  
SOUTH ELEVATION  
928 ORTON RD, OLDBURY, WA 6121



© Telstra Corporation Limited ABN 33 051 775 556 All rights reserved.

DWG NO. **W109496** SHT NO. S3

Ordinary Council Meeting - 16 November 2020

TELSTRA ANTENNA CONFIGURATION TABLE

ANTENNA No	ANTENNA TYPE & SIZE H x W x D	ANTENNA ACTION REQUIRED	ANTENNA HEIGHT C/L A.G.L.	ANTENNA BEARING (x°T)	SECTOR NO. & TECHNOLOGY
A1	ARGUS RVVPX310.11B-T2 PANEL 2533 x 35 x 208mm	INSTALL	39.3m	70°	S1: LTE700 / S1: NR850 S1: LTE700 / S1: NR850
					S1: LTE1800 / S1: LTE2100 S1: LTE1800 / S1: LTE2100
					S1: LTE1800 / S1: LTE2100 S1: LTE1800 / S1: LTE2100
A2	ARGUS RVVPX310.11B-T2 PANEL 2533 x 35 x 208mm	INSTALL	39.3m	70°	S1: LTE700 S1: LTE700
					S1: LTE2600 S1: LTE2600
					S1: LTE2600 S1: LTE2600
A3	ARGUS RVVPX310.11B-T2 PANEL 2533 x 35 x 208mm	INSTALL	39.3m	160°	S2: LTE700 / S2: NR850 S2: LTE700 / S2: NR850
					S2: LTE1800 / S2: LTE2100 S2: LTE1800 / S2: LTE2100
					S2: LTE1800 / S2: LTE2100 S2: LTE1800 / S2: LTE2100
A4	ARGUS RVVPX310.11B-T2 PANEL 2533 x 35 x 208mm	INSTALL	39.3m	160°	S2: LTE700 S2: LTE700
					S2: LTE2600 S2: LTE2600
					S2: LTE2600 S2: LTE2600
A5	ARGUS RVVPX310.11B-T2 PANEL 2533 x 35 x 208mm	INSTALL	39.3m	250°	S3: LTE700 / S3: NR850 S3: LTE700 / S3: NR850
					S3: LTE1800 / S3: LTE2100 S3: LTE1800 / S3: LTE2100
					S3: LTE1800 / S3: LTE2100 S3: LTE1800 / S3: LTE2100
A6	ARGUS RVVPX310.11B-T2 PANEL 2533 x 35 x 208mm	INSTALL	39.3m	250°	S3: LTE700 S3: LTE700
					S3: LTE2600 S3: LTE2600
					S3: LTE2600 S3: LTE2600
A7	ERICSSON AIR6488 PANEL 810 x 400 x 200mm	INSTALL	39.3m	70°	S1: NR3600 S1: NR3600
A8	ERICSSON AIR6488 PANEL 810 x 400 x 200mm	INSTALL	39.3m	160°	S2: NR3600 S2: NR3600
A9	ERICSSON AIR6488 PANEL 810 x 400 x 200mm	INSTALL	39.3m	250°	S3: NR3600 S3: NR3600
A200	ERICSSON-KRE 101 2082/1 GPS ANTENNA	INSTALL	3.5m	0°	-

**COMPLIANCE BOX**  
 COMPLETED AS PER DESIGN   
 ALTERATIONS IN RED   
 NAME (PRINT) \_\_\_\_\_  
 SIGNATURE \_\_\_\_\_ DATE \_\_\_\_\_

**PRELIMINARY**

TO BE READ IN CONJUNCTION WITH SHEETS S1, S1-1, S1-2 & S3.

ORDER	DRAWN	CHKD	AMENDMENT	EXAM	APPD	DATE	ISS
WA07145.01	RH	AH	PRELIMINARY - 30084149W0062 VPL - LTE700/LTE1800/LTE2100/NR850	SZ	RO	27.02.20	1

**Telstra**

**MOBILE NETWORK SITE 323359**  
**BYFORD WEST**  
 ANTENNA CONFIGURATION TABLE  
 928 ORTON RD, OLDBURY, WA 6121



© Telstra Corporation Limited ABN 33 051 775 556 All rights reserved.

DWG NO. **W109496** SHT NO. S3-1

Telstra Networks Wireless Program Delivery Template - 017868P02 Issue 12 11/04/2016

**Appendix C – Environmental EME Report**

# Environmental EME Report

<b>Location</b>	928 ORTON RD, OLDBURY WA 6121		
<b>Date</b>	10/05/2020	<b>RFNSA No.</b>	6121005

## How does this report work?

This report provides a summary of levels of radiofrequency (RF) electromagnetic energy (EME) around the wireless base station at 928 ORTON RD, OLDBURY WA 6121. These levels have been calculated by Visionstream using methodology developed by the Australian Radiation Protection and Nuclear Safety Agency (ARPANSA).

A document describing how to interpret this report is available at ARPANSA’s website:

[A Guide to the Environmental Report.](#)

## A snapshot of calculated EME levels at this site

There are currently no existing radio systems for this site.

The maximum EME level calculated for the **proposed** changes at this site is

# 2.12%

out of 100% of the public exposure limit, 76 m from the location.

**EME levels with the proposed changes**

Distance from the site	Percentage of the public exposure limit
0-50 m	1.29%
50-100 m	2.12%
100-200 m	1.75%
200-300 m	0.81%
300-400 m	0.59%
400-500 m	0.35%

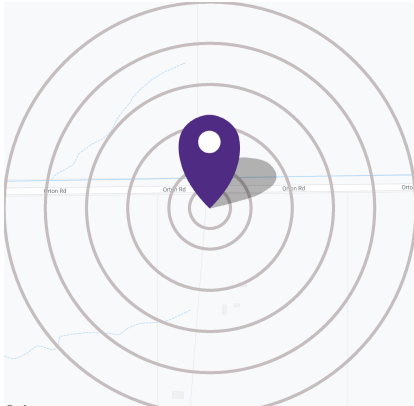

For additional information please refer to the EME ARPANSA Report annexure for this site which can be found at <http://www.rfnsa.com.au/6121005>.

## Radio systems at the site

This base station currently has equipment for transmitting the services listed under the existing configuration. The proposal would modify the base station to include all the services listed under the proposed configuration.

Carrier	Existing		Proposed	
	Systems	Configuration	Systems	Configuration
Telstra			4G, 5G	LTE700 (proposed), LTE2600 (proposed), LTE1800 (proposed), LTE2100 (proposed), NR850 (proposed), NR3500 (proposed)

## An in-depth look at calculated EME levels at this site

This table provides calculations of RF EME at different distances from the base station for emissions from existing equipment alone and for emissions from existing equipment and proposed equipment combined. All EME levels are relative to 1.5 m above ground and all distances from the site are in 360° circular bands.

Distance from the site	Existing configuration			Proposed configuration		
	Electric field (V/m)	Power density (mW/m <sup>2</sup> )	Percentage of the public exposure limit	Electric field (V/m)	Power density (mW/m <sup>2</sup> )	Percentage of the public exposure limit
0-50m				6.95	128.12	1.29%
50-100m				8.9	210.3	2.12%
100-200m				8.097	173.89	1.75%
200-300m				5.18	71.16	0.81%
300-400m				4.26	48.11	0.59%
400-500m				3.29	28.68	0.35%

## Calculated EME levels at other areas of interest

This table contains calculations of the maximum EME levels at selected areas of interest, identified through consultation requirements of the [Communications Alliance Ltd Deployment Code C564:2018](#) or other means. Calculations are performed over the indicated height range and include all existing and any proposed radio systems for this site.

### Maximum cumulative EME level for the configuration

Location	Height range	Electric field (V/m)	Power density (mW/m <sup>2</sup> )	Percentage of the public exposure limit
No locations identified				



**Appendix D – Site Photographs**



**View facing West towards the proposed site. Orange arrow shows indicative location.**



View facing East towards the proposed site. Orange arrow shows indicative location.

**Appendix E – Fact Sheets**



## Mobile Phone Base Stations and Health

**Based on current research there are no established health effects that can be attributed to the low RF EME exposure from mobile phone base station antennas.**

### Introduction

There are mobile phone base station antennas on towers and buildings throughout Australia's populated areas. These antennas are part of the mobile phone network and they emit low level radiofrequency (RF) electromagnetic energy (EME). This fact sheet provides information about concern of adverse health effects arising from exposure to RF EME from base station antennas.

### How does the mobile phone network operate?

When a call is made from a mobile phone, RF signals are transmitted between its antenna and the antenna at a nearby base station. The phone call is then routed through the phone network to the destination phone. Base station antennas must be elevated and located clear of physical obstruction to ensure wide coverage.

In an area of increasing mobile phone use the number of additional base stations needed to maintain service quality increases, even in areas where mobile network coverage already exists. If this is not done the mobile network will not operate properly and, as a result, mobile phone users may not be able to connect to their network.

### Are base stations regulated in Australia?

The RF EME emissions from mobile phone base stations and other communications installations are regulated by the Australian Communications



and Media Authority (ACMA). The ACMA's regulatory arrangements require base stations to comply with the exposure limits in the ARPANSA RF Standard. The ARPANSA Standard is designed to protect people of all ages and health status against all known adverse health effects from exposure to RF EME. The ARPANSA Standard is based on scientific research that shows the levels at which harmful effects occur and it sets limits, based on international guidelines, well below these harmful levels.

The ACMA also requires base stations to comply with an industry code of practice which requires telecommunications carriers to inform and consult with the local community when planning, installing or upgrading base stations.

### How much RF EME are people exposed to from base stations?

The maximum levels of exposure of RF EME from base stations may be calculated from details of the equipment installed. These calculations are made available in the ARPANSA EME reports provided by the telecommunications companies on the Radio Frequency National Site Archive website, [www.rfnsa.com.au](http://www.rfnsa.com.au). The base station sites may be located by searching by postcode or town.

EME exposure to the public from base stations is typically hundreds of times below the limits of the ARPANSA RF Standard.

## Do base stations cause any health effects?

Health authorities around the world, including ARPANSA and the World Health Organization, have examined the scientific evidence regarding possible health effects from base stations. Current research indicates that there are no established health effects from the low exposure to the RF EME from mobile phone base station antennas.

## How about people who work very close to base station antennas?

Workers accessing rooftops and towers that house base station antennas must consult with building and facility management before entering the site. A guide to working safely near mobile phone base stations is available at <https://www.radioworksafes.com.au/>.

## Conclusion

No adverse health effects are expected from continuous exposure to the RF EME emitted by the antennas on mobile phone base stations.

ARPANSA will continue to review the research into potential health effects of RF EME emissions from mobile phone base stations and other sources in order to provide accurate and up-to-date advice.

### Useful Links

ARPANSA fact sheet on RF EME  
[www.arpansa.gov.au/RadiationProtection/basics/rf.cfm](http://www.arpansa.gov.au/RadiationProtection/basics/rf.cfm)

The ARPANSA RF Standard  
[www.arpansa.gov.au/Publications/codes/rps3.cfm](http://www.arpansa.gov.au/Publications/codes/rps3.cfm)

WHO fact sheet on base stations  
[www.who.int/peh-emf/publications/facts/fs304/en/](http://www.who.int/peh-emf/publications/facts/fs304/en/)

AMTA information on Australian base stations  
[www.rfnsa.com.au](http://www.rfnsa.com.au)  
[www.mobilesitesafety.com.au](http://www.mobilesitesafety.com.au)



**Appendix F – Environment Analysis Report (EPBC)**



# EPBC Act Protected Matters Report

This report provides general guidance on matters of national environmental significance and other matters protected by the EPBC Act in the area you have selected.

Information on the coverage of this report and qualifications on data supporting this report are contained in the caveat at the end of the report.

Information is available about [Environment Assessments](#) and the EPBC Act including significance guidelines, forms and application process details.

Report created: 25/07/19 15:25:42

[Summary](#)

[Details](#)

[Matters of NES](#)

[Other Matters Protected by the EPBC Act](#)

[Extra Information](#)

[Caveat](#)

[Acknowledgements](#)

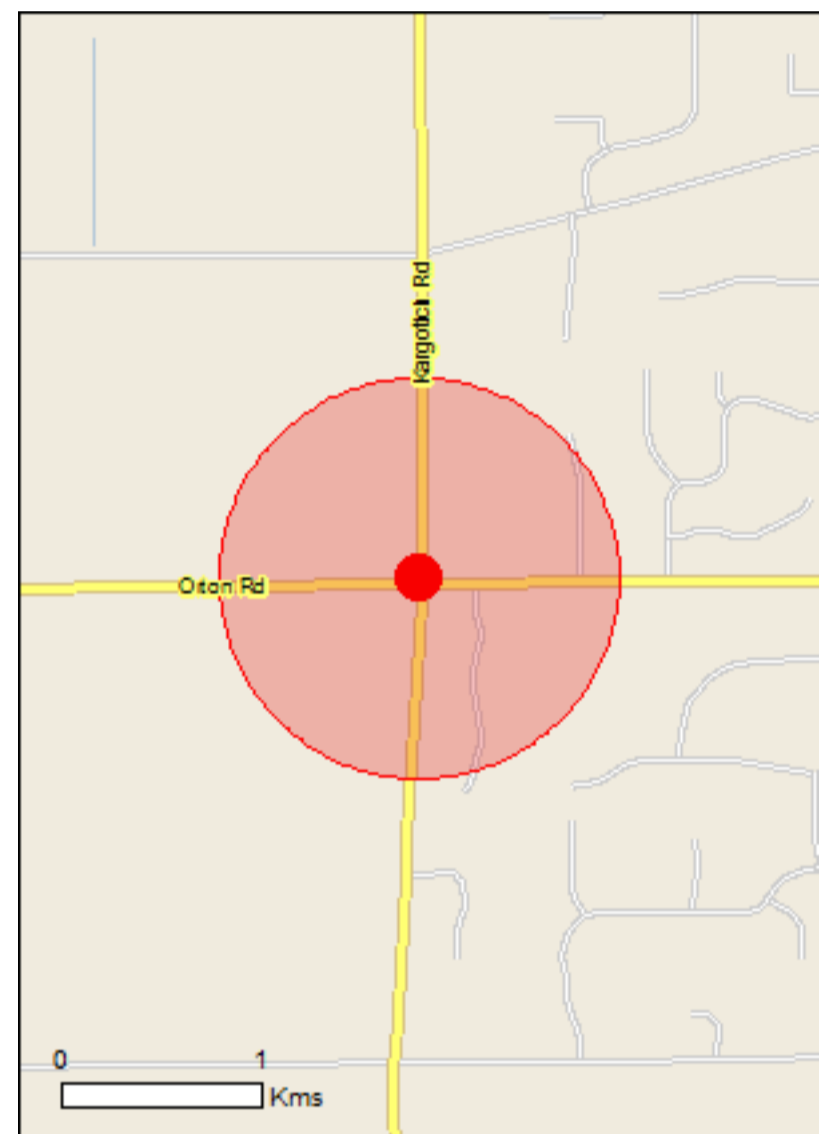

This map may contain data which are  
©Commonwealth of Australia  
(Geoscience Australia), ©PSMA 2010

[Coordinates](#)

[Buffer: 1.0Km](#)

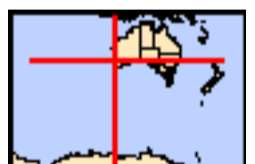

# Summary

## Matters of National Environmental Significance

This part of the report summarises the matters of national environmental significance that may occur in, or may relate to, the area you nominated. Further information is available in the detail part of the report, which can be accessed by scrolling or following the links below. If you are proposing to undertake an activity that may have a significant impact on one or more matters of national environmental significance then you should consider the [Administrative Guidelines on Significance](#).

<a href="#">World Heritage Properties:</a>	None
<a href="#">National Heritage Places:</a>	None
<a href="#">Wetlands of International Importance:</a>	2
<a href="#">Great Barrier Reef Marine Park:</a>	None
<a href="#">Commonwealth Marine Area:</a>	None
<a href="#">Listed Threatened Ecological Communities:</a>	2
<a href="#">Listed Threatened Species:</a>	21
<a href="#">Listed Migratory Species:</a>	9

## Other Matters Protected by the EPBC Act

This part of the report summarises other matters protected under the Act that may relate to the area you nominated. Approval may be required for a proposed activity that significantly affects the environment on Commonwealth land, when the action is outside the Commonwealth land, or the environment anywhere when the action is taken on Commonwealth land. Approval may also be required for the Commonwealth or Commonwealth agencies proposing to take an action that is likely to have a significant impact on the environment anywhere.

The EPBC Act protects the environment on Commonwealth land, the environment from the actions taken on Commonwealth land, and the environment from actions taken by Commonwealth agencies. As heritage values of a place are part of the 'environment', these aspects of the EPBC Act protect the Commonwealth Heritage values of a Commonwealth Heritage place. Information on the new heritage laws can be found at <http://www.environment.gov.au/heritage>

A [permit](#) may be required for activities in or on a Commonwealth area that may affect a member of a listed threatened species or ecological community, a member of a listed migratory species, whales and other cetaceans, or a member of a listed marine species.

<a href="#">Commonwealth Land:</a>	None
<a href="#">Commonwealth Heritage Places:</a>	None
<a href="#">Listed Marine Species:</a>	14
<a href="#">Whales and Other Cetaceans:</a>	None
<a href="#">Critical Habitats:</a>	None
<a href="#">Commonwealth Reserves Terrestrial:</a>	None
<a href="#">Australian Marine Parks:</a>	None

## Extra Information

This part of the report provides information that may also be relevant to the area you have nominated.

<a href="#">State and Territory Reserves:</a>	None
<a href="#">Regional Forest Agreements:</a>	None
<a href="#">Invasive Species:</a>	36
<a href="#">Nationally Important Wetlands:</a>	None
<a href="#">Key Ecological Features (Marine)</a>	None



# Details

## Matters of National Environmental Significance

Wetlands of International Importance (Ramsar)	[ Resource Information ]
Name	Proximity
<a href="#">Forrestdale and thomsons lakes</a>	Within 10km of Ramsar
<a href="#">Peel-yalgorup system</a>	30 - 40km upstream

Listed Threatened Ecological Communities	[ Resource Information ]
For threatened ecological communities where the distribution is well known, maps are derived from recovery plans, State vegetation maps, remote sensing imagery and other sources. Where threatened ecological community distributions are less well known, existing vegetation maps and point location data are used to produce indicative distribution maps.	

Name	Status	Type of Presence
<a href="#">Banksia Woodlands of the Swan Coastal Plain ecological community</a>	Endangered	Community may occur within area
<a href="#">Tuart (Eucalyptus gomphocephala) Woodlands and Forests of the Swan Coastal Plain ecological community</a>	Critically Endangered	Community may occur within area

Listed Threatened Species	[ Resource Information ]	
Name	Status	Type of Presence
<b>Birds</b>		
<a href="#">Calidris ferruginea</a> Curlew Sandpiper [856]	Critically Endangered	Species or species habitat may occur within area
<a href="#">Calyptorhynchus banksii naso</a> Forest Red-tailed Black-Cockatoo, Karrak [67034]	Vulnerable	Species or species habitat likely to occur within area
<a href="#">Calyptorhynchus baudinii</a> Baudin's Cockatoo, Long-billed Black-Cockatoo [769]	Endangered	Roosting known to occur within area
<a href="#">Calyptorhynchus latirostris</a> Carnaby's Cockatoo, Short-billed Black-Cockatoo [59523]	Endangered	Breeding likely to occur within area
<a href="#">Leipoa ocellata</a> Malleefowl [934]	Vulnerable	Species or species habitat may occur within area
<a href="#">Numenius madagascariensis</a> Eastern Curlew, Far Eastern Curlew [847]	Critically Endangered	Species or species habitat may occur within area
<a href="#">Rostratula australis</a> Australian Painted-snipe, Australian Painted Snipe [77037]	Endangered	Species or species habitat may occur within area
<b>Mammals</b>		
<a href="#">Bettongia penicillata ogilbyi</a> Woylie [66844]	Endangered	Species or species habitat likely to occur within area
<a href="#">Dasyurus geoffroi</a> Chuditch, Western Quoll [330]	Vulnerable	Species or species habitat likely to occur within area

Name	Status	Type of Presence
<a href="#">Pseudocheirus occidentalis</a> Western Ringtail Possum, Ngwayir, Womp, Woder, Ngoor, Ngoolangit [25911]	Critically Endangered	Species or species habitat may occur within area
<a href="#">Setonix brachyurus</a> Quokka [229]	Vulnerable	Species or species habitat may occur within area
<b>Plants</b>		
<a href="#">Andersonia gracilis</a> Slender Andersonia [14470]	Endangered	Species or species habitat may occur within area
<a href="#">Diuris micrantha</a> Dwarf Bee-orchid [55082]	Vulnerable	Species or species habitat likely to occur within area
<a href="#">Diuris purdiei</a> Purdie's Donkey-orchid [12950]	Endangered	Species or species habitat known to occur within area
<a href="#">Drakaea elastica</a> Glossy-leaved Hammer Orchid, Glossy-leaved Hammer Orchid, Warty Hammer Orchid [16753]	Endangered	Species or species habitat may occur within area
<a href="#">Drakaea micrantha</a> Dwarf Hammer-orchid [56755]	Vulnerable	Species or species habitat may occur within area
<a href="#">Eucalyptus x balanites</a> Cadda Road Mallee, Cadda Mallee [87816]	Endangered	Species or species habitat likely to occur within area
<a href="#">Grevillea curviloba subsp. incurva</a> Narrow curved-leaf Grevillea [64909]	Endangered	Species or species habitat may occur within area
<a href="#">Synaphea sp. Fairbridge Farm (D. Papenfus 696)</a> Selena's Synaphea [82881]	Critically Endangered	Species or species habitat likely to occur within area
<a href="#">Synaphea sp. Serpentine (G.R. Brand 103)</a> [86879]	Critically Endangered	Species or species habitat may occur within area
<a href="#">Thelymitra stellata</a> Star Sun-orchid [7060]	Endangered	Species or species habitat may occur within area
<b>Listed Migratory Species</b>		<b>[ Resource Information ]</b>
* Species is listed under a different scientific name on the EPBC Act - Threatened Species list.		
Name	Threatened	Type of Presence
<b>Migratory Marine Birds</b>		
<a href="#">Apus pacificus</a> Fork-tailed Swift [678]		Species or species habitat likely to occur within area
<b>Migratory Terrestrial Species</b>		
<a href="#">Motacilla cinerea</a> Grey Wagtail [642]		Species or species habitat may occur within area
<b>Migratory Wetlands Species</b>		
<a href="#">Actitis hypoleucos</a> Common Sandpiper [59309]		Species or species habitat may occur within area
<a href="#">Calidris acuminata</a> Sharp-tailed Sandpiper [874]		Species or species habitat may occur within area

Name	Threatened	Type of Presence
<a href="#">Calidris ferruginea</a> Curlew Sandpiper [856]	Critically Endangered	Species or species habitat may occur within area
<a href="#">Calidris melanotos</a> Pectoral Sandpiper [858]		Species or species habitat may occur within area
<a href="#">Numenius madagascariensis</a> Eastern Curlew, Far Eastern Curlew [847]	Critically Endangered	Species or species habitat may occur within area
<a href="#">Pandion haliaetus</a> Osprey [952]		Species or species habitat may occur within area
<a href="#">Tringa nebularia</a> Common Greenshank, Greenshank [832]		Species or species habitat likely to occur within area

## Other Matters Protected by the EPBC Act

### Listed Marine Species [ [Resource Information](#) ]

\* Species is listed under a different scientific name on the EPBC Act - Threatened Species list.

Name	Threatened	Type of Presence
<b>Birds</b>		
<a href="#">Actitis hypoleucos</a> Common Sandpiper [59309]		Species or species habitat may occur within area
<a href="#">Apus pacificus</a> Fork-tailed Swift [678]		Species or species habitat likely to occur within area
<a href="#">Ardea alba</a> Great Egret, White Egret [59541]		Species or species habitat likely to occur within area
<a href="#">Ardea ibis</a> Cattle Egret [59542]		Species or species habitat may occur within area
<a href="#">Calidris acuminata</a> Sharp-tailed Sandpiper [874]		Species or species habitat may occur within area
<a href="#">Calidris ferruginea</a> Curlew Sandpiper [856]	Critically Endangered	Species or species habitat may occur within area
<a href="#">Calidris melanotos</a> Pectoral Sandpiper [858]		Species or species habitat may occur within area
<a href="#">Haliaeetus leucogaster</a> White-bellied Sea-Eagle [943]		Species or species habitat likely to occur within area
<a href="#">Merops ornatus</a> Rainbow Bee-eater [670]		Species or species habitat may occur within area
<a href="#">Motacilla cinerea</a> Grey Wagtail [642]		Species or species habitat may occur within area

Name	Threatened	Type of Presence
<a href="#">Numenius madagascariensis</a> Eastern Curlew, Far Eastern Curlew [847]	Critically Endangered	Species or species habitat may occur within area
<a href="#">Pandion haliaetus</a> Osprey [952]		Species or species habitat may occur within area
<a href="#">Rostratula benghalensis (sensu lato)</a> Painted Snipe [889]	Endangered*	Species or species habitat may occur within area
<a href="#">Tringa nebularia</a> Common Greenshank, Greenshank [832]		Species or species habitat likely to occur within area

## Extra Information

### Invasive Species

### [ Resource Information ]

Weeds reported here are the 20 species of national significance (WoNS), along with other introduced plants that are considered by the States and Territories to pose a particularly significant threat to biodiversity. The following feral animals are reported: Goat, Red Fox, Cat, Rabbit, Pig, Water Buffalo and Cane Toad. Maps from Landscape Health Project, National Land and Water Resources Audit, 2001.

Name	Status	Type of Presence
<b>Birds</b>		
Acridotheres tristis Common Myna, Indian Myna [387]		Species or species habitat likely to occur within area
Anas platyrhynchos Mallard [974]		Species or species habitat likely to occur within area
Carduelis carduelis European Goldfinch [403]		Species or species habitat likely to occur within area
Columba livia Rock Pigeon, Rock Dove, Domestic Pigeon [803]		Species or species habitat likely to occur within area
Passer domesticus House Sparrow [405]		Species or species habitat likely to occur within area
Passer montanus Eurasian Tree Sparrow [406]		Species or species habitat likely to occur within area
Streptopelia chinensis Spotted Turtle-Dove [780]		Species or species habitat likely to occur within area
Streptopelia senegalensis Laughing Turtle-dove, Laughing Dove [781]		Species or species habitat likely to occur within area
Sturnus vulgaris Common Starling [389]		Species or species habitat likely to occur within area
Turdus merula Common Blackbird, Eurasian Blackbird [596]		Species or species habitat likely to occur within area
<b>Mammals</b>		

Name	Status	Type of Presence 10.1.4 - attachment 1
Bos taurus Domestic Cattle [16]		Species or species habitat likely to occur within area
Canis lupus familiaris Domestic Dog [82654]		Species or species habitat likely to occur within area
Felis catus Cat, House Cat, Domestic Cat [19]		Species or species habitat likely to occur within area
Funambulus pennantii Northern Palm Squirrel, Five-striped Palm Squirrel [129]		Species or species habitat likely to occur within area
Mus musculus House Mouse [120]		Species or species habitat likely to occur within area
Oryctolagus cuniculus Rabbit, European Rabbit [128]		Species or species habitat likely to occur within area
Rattus norvegicus Brown Rat, Norway Rat [83]		Species or species habitat likely to occur within area
Rattus rattus Black Rat, Ship Rat [84]		Species or species habitat likely to occur within area
Vulpes vulpes Red Fox, Fox [18]		Species or species habitat likely to occur within area
<b>Plants</b>		
Asparagus asparagoides Bridal Creeper, Bridal Veil Creeper, Smilax, Florist's Smilax, Smilax Asparagus [22473]		Species or species habitat likely to occur within area
Brachiaria mutica Para Grass [5879]		Species or species habitat may occur within area
Cenchrus ciliaris Buffel-grass, Black Buffel-grass [20213]		Species or species habitat may occur within area
Chrysanthemoides monilifera Bitou Bush, Boneseed [18983]		Species or species habitat may occur within area
Chrysanthemoides monilifera subsp. monilifera Boneseed [16905]		Species or species habitat likely to occur within area
Genista monspessulana Montpellier Broom, Cape Broom, Canary Broom, Common Broom, French Broom, Soft Broom [20126]		Species or species habitat likely to occur within area
Genista sp. X Genista monspessulana Broom [67538]		Species or species habitat may occur within area
Lantana camara Lantana, Common Lantana, Kamara Lantana, Large-leaf Lantana, Pink Flowered Lantana, Red Flowered Lantana, Red-Flowered Sage, White Sage, Wild Sage [10892]		Species or species habitat likely to occur within area
Lycium ferocissimum African Boxthorn, Boxthorn [19235]		Species or species habitat likely to occur

Name	Status	Type of Presence 10.1.4 - attachment 1 within area
Olea europaea Olive, Common Olive [9160]		Species or species habitat may occur within area
Pinus radiata Radiata Pine Monterey Pine, Insignis Pine, Wilding Pine [20780]		Species or species habitat may occur within area
Rubus fruticosus aggregate Blackberry, European Blackberry [68406]		Species or species habitat likely to occur within area
Salix spp. except S.babylonica, S.x calodendron & S.x reichardtii Willows except Weeping Willow, Pussy Willow and Sterile Pussy Willow [68497]		Species or species habitat likely to occur within area
Salvinia molesta Salvinia, Giant Salvinia, Aquarium Watermoss, Kariba Weed [13665]		Species or species habitat likely to occur within area
Solanum elaeagnifolium Silver Nightshade, Silver-leaved Nightshade, White Horse Nettle, Silver-leaf Nightshade, Tomato Weed, White Nightshade, Bull-nettle, Prairie-berry, Satansbos, Silver-leaf Bitter-apple, Silverleaf-nettle, Trompillo [12323]		Species or species habitat likely to occur within area
Tamarix aphylla Athel Pine, Athel Tree, Tamarisk, Athel Tamarisk, Athel Tamarix, Desert Tamarisk, Flowering Cypress, Salt Cedar [16018]		Species or species habitat likely to occur within area
<b>Reptiles</b>		
Hemidactylus frenatus Asian House Gecko [1708]		Species or species habitat likely to occur within area

# Caveat

The information presented in this report has been provided by a range of data sources as acknowledged at the end of the report.

This report is designed to assist in identifying the locations of places which may be relevant in determining obligations under the Environment Protection and Biodiversity Conservation Act 1999. It holds mapped locations of World and National Heritage properties, Wetlands of International and National Importance, Commonwealth and State/Territory reserves, listed threatened, migratory and marine species and listed threatened ecological communities. Mapping of Commonwealth land is not complete at this stage. Maps have been collated from a range of sources at various resolutions.

Not all species listed under the EPBC Act have been mapped (see below) and therefore a report is a general guide only. Where available data supports mapping, the type of presence that can be determined from the data is indicated in general terms. People using this information in making a referral may need to consider the qualifications below and may need to seek and consider other information sources.

For threatened ecological communities where the distribution is well known, maps are derived from recovery plans, State vegetation maps, remote sensing imagery and other sources. Where threatened ecological community distributions are less well known, existing vegetation maps and point location data are used to produce indicative distribution maps.

Threatened, migratory and marine species distributions have been derived through a variety of methods. Where distributions are well known and if time permits, maps are derived using either thematic spatial data (i.e. vegetation, soils, geology, elevation, aspect, terrain, etc) together with point locations and described habitat; or environmental modelling (MAXENT or BIOCLIM habitat modelling) using point locations and environmental data layers.

Where very little information is available for species or large number of maps are required in a short time-frame, maps are derived either from 0.04 or 0.02 decimal degree cells; by an automated process using polygon capture techniques (static two kilometre grid cells, alpha-hull and convex hull); or captured manually or by using topographic features (national park boundaries, islands, etc). In the early stages of the distribution mapping process (1999-early 2000s) distributions were defined by degree blocks, 100K or 250K map sheets to rapidly create distribution maps. More reliable distribution mapping methods are used to update these distributions as time permits.

Only selected species covered by the following provisions of the EPBC Act have been mapped:

- migratory and
- marine

The following species and ecological communities have not been mapped and do not appear in reports produced from this database:

- threatened species listed as extinct or considered as vagrants
- some species and ecological communities that have only recently been listed
- some terrestrial species that overfly the Commonwealth marine area
- migratory species that are very widespread, vagrant, or only occur in small numbers

The following groups have been mapped, but may not cover the complete distribution of the species:

- non-threatened seabirds which have only been mapped for recorded breeding sites
- seals which have only been mapped for breeding sites near the Australian continent

Such breeding sites may be important for the protection of the Commonwealth Marine environment.

# Coordinates

-32.2357 115.95307

# Acknowledgements

This database has been compiled from a range of data sources. The department acknowledges the following custodians who have contributed valuable data and advice:

- [-Office of Environment and Heritage, New South Wales](#)
- [-Department of Environment and Primary Industries, Victoria](#)
- [-Department of Primary Industries, Parks, Water and Environment, Tasmania](#)
- [-Department of Environment, Water and Natural Resources, South Australia](#)
- [-Department of Land and Resource Management, Northern Territory](#)
- [-Department of Environmental and Heritage Protection, Queensland](#)
- [-Department of Parks and Wildlife, Western Australia](#)
- [-Environment and Planning Directorate, ACT](#)
- [-Birdlife Australia](#)
- [-Australian Bird and Bat Banding Scheme](#)
- [-Australian National Wildlife Collection](#)
- Natural history museums of Australia
- [-Museum Victoria](#)
- [-Australian Museum](#)
- [-South Australian Museum](#)
- [-Queensland Museum](#)
- [-Online Zoological Collections of Australian Museums](#)
- [-Queensland Herbarium](#)
- [-National Herbarium of NSW](#)
- [-Royal Botanic Gardens and National Herbarium of Victoria](#)
- [-Tasmanian Herbarium](#)
- [-State Herbarium of South Australia](#)
- [-Northern Territory Herbarium](#)
- [-Western Australian Herbarium](#)
- [-Australian National Herbarium, Canberra](#)
- [-University of New England](#)
- [-Ocean Biogeographic Information System](#)
- [-Australian Government, Department of Defence Forestry Corporation, NSW](#)
- [-Geoscience Australia](#)
- [-CSIRO](#)
- [-Australian Tropical Herbarium, Cairns](#)
- [-eBird Australia](#)
- [-Australian Government – Australian Antarctic Data Centre](#)
- [-Museum and Art Gallery of the Northern Territory](#)
- [-Australian Government National Environmental Science Program](#)
- [-Australian Institute of Marine Science](#)
- [-Reef Life Survey Australia](#)
- [-American Museum of Natural History](#)
- [-Queen Victoria Museum and Art Gallery, Inveresk, Tasmania](#)
- [-Tasmanian Museum and Art Gallery, Hobart, Tasmania](#)
- Other groups and individuals

The Department is extremely grateful to the many organisations and individuals who provided expert advice and information on numerous draft distributions.

Please feel free to provide feedback via the [Contact Us](#) page.

© Commonwealth of Australia  
 Department of the Environment  
 GPO Box 787  
 Canberra ACT 2601 Australia  
 +61 2 6274 1111





**Appendix G – Refusal Notice for previous Candidate at 624 Kargotich Road Oakford**



All enquiries to Development Services on 9526 1111  
Our ref: PA19/856: HR:wj

15 October 2019

Visionstream Pty Ltd  
37 Kewdale Road  
WELSHPOOL WA 6106

Via email: [matthew.fletcher@visionstream.com.au](mailto:matthew.fletcher@visionstream.com.au)

Dear Sir/Madam,

**Proposed Telecommunications Facility  
Lot 1378, 624 Kargotich Road, Oakford**

I refer to your application, received 21 August 2019, for approval to commence development on the aforementioned lot.

In accordance with the provisions of the Shire's Town Planning Scheme No. 2 and the authority delegated to Council under the provisions of the Metropolitan Region Scheme, your application to commence development has been refused. Attached is the Notice of Determination of Application for Development Approval stating the reason(s) for which development was refused.

Should you be aggrieved by any of the decision or any conditions imposed, you have the right under the *Planning and Development Act 2005* to have the decision reviewed by the State Administrative Tribunal. Applications for review must be submitted to the Tribunal within 28 days of the date on the decision notice. Further information can be obtained by calling the Tribunal on (08) 9219 3111 or by visiting their website at [www.sat.justice.wa.gov.au](http://www.sat.justice.wa.gov.au).

Yours faithfully

A handwritten signature in black ink that reads "H O'Brien".

Heather O'Brien  
Coordinator Statutory Planning

*Planning and Development Act 2005*  
Shire of Serpentine Jarrahdale  
**Notice of Determination on Application for  
Development Approval**

---

Property File:	A406217	Application No:	PA19/856
Location:	624 Kargotich Road, Oakford		
Lot:	1378	Plan/Diagram:	218320
Vol. No:	3102	Folio No:	151
Application Date:	21 August 2019	Received On:	21 August 2019

Description of Proposed Development: Telecommunications Facility

Use Class: Radio, T.V and Communications Instalment

Date of Determination: 15 October 2019

That the Coordinator Statutory Planning REFUSES Development Approval under Delegated Authority 12.1.1 pursuant to Clause 68(2) of the Deemed Provisions of *Planning and Development (Local Planning Schemes) Regulations 2015* for a Telecommunications Facility subject to the following reasons for refusal:

**Reasons:**

1. The proposed development would be at odds with the established rural character of the area and is likely to adversely impact on the rural lifestyle of surrounding residents, which is contradictory to the objectives for the Rural Policy Area under the Rural Strategy Review 2013.
2. The proposed development would be highly visible from two public roads and incapable of being appropriately screened as a result of the small lot size and proximity to both road reserves. The visual impact of the proposed development is inconsistent with the provisions and objectives of State Planning Policy 5.2 – Telecommunications Infrastructure and Local Planning Policy 4.6 – Telecommunications Infrastructure.
3. The height, scale and appearance of the proposed development is incompatible with its setting taking into account the visibility of the development in the proposed location and is inconsistent with clause 67(m) of the Deemed Provisions.

NOTE 1: If an applicant or owner is aggrieved by this determination there is a right of review by the State Administrative Tribunal in accordance with the *Planning and Development Act 2005* Part 14. An application must be made within 28 days of the determination.

Signed:



Dated: 15 October 2019

For and on behalf of the Shire of Serpentine Jarrahdale



## Proposed Monopole - Byford West

Indicative view from Orton Road, approximately 200m west of the proposed site.



## Proposed Monopole - Byford West

Indicative view from Orton Road, approximately 200m east of the proposed site.

Photos from this location

Photos from this location

