

NO. 1	1:100
NO. 2	1:100
NO. 3	1:100
NO. 4	1:100
NO. 5	1:100
NO. 6	1:100
NO. 7	1:100
NO. 8	1:100
NO. 9	1:100
NO. 10	1:100
NO. 11	1:100
NO. 12	1:100
NO. 13	1:100
NO. 14	1:100
NO. 15	1:100
NO. 16	1:100
NO. 17	1:100
NO. 18	1:100
NO. 19	1:100
NO. 20	1:100
NO. 21	1:100
NO. 22	1:100
NO. 23	1:100
NO. 24	1:100
NO. 25	1:100
NO. 26	1:100
NO. 27	1:100
NO. 28	1:100
NO. 29	1:100
NO. 30	1:100
NO. 31	1:100
NO. 32	1:100
NO. 33	1:100
NO. 34	1:100
NO. 35	1:100
NO. 36	1:100
NO. 37	1:100
NO. 38	1:100
NO. 39	1:100
NO. 40	1:100
NO. 41	1:100
NO. 42	1:100
NO. 43	1:100
NO. 44	1:100
NO. 45	1:100
NO. 46	1:100
NO. 47	1:100
NO. 48	1:100
NO. 49	1:100
NO. 50	1:100



Existing  
1.8m(H)  
Timber-Colorbond-  
Wilderness.

Proposed extension to  
fencing - 1.8m (H)  
Timber-Colorbond-  
Wilderness.  
Length of extension ->  
4.8m total.

NOTE: ALL FEATURES SHOWN ON  
SUMMARY ARE PROVIDED FROM  
EXISTING RECORDS & FIELD WORK  
AND NOT BE CONSIDERED AS A  
WARRANTY OF ACCURACY.

NOTE: ALL DIMENSIONS GIVEN ARE  
UNLESS OTHERWISE SPECIFIED BY  
OTHER NOTATION.

NOTE: ALL DIMENSIONS GIVEN ARE  
UNLESS OTHERWISE SPECIFIED BY  
OTHER NOTATION.

**OTTAGE & ENGINEERING**  
SURVEYS

Soil Description  
Fill Sand with Trace of Gravel  
Clayey Sand with Gravel  
Hard Gravel  
Reddish Gravelly Clayey Sand  
Reddish  
Reticular to Heavy

Builder - Central Using the Home Builder  
C14911 Sewer  
LOT 226 Aquaria Road, Darling Downs



Proposed fencing extension application (4.8m total length) – 28 Aquanita Rise, Darling Downs WA 6122

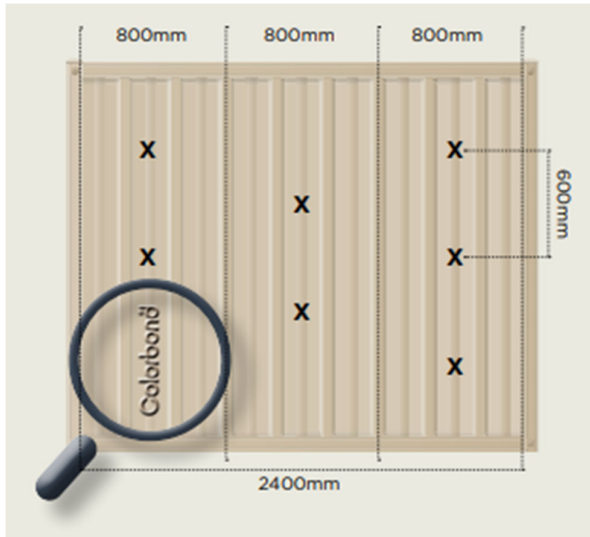

Annotation of fencing panelling above. Please note – application is for two (2) of the above sections – equalling a total of 4.8m metres.

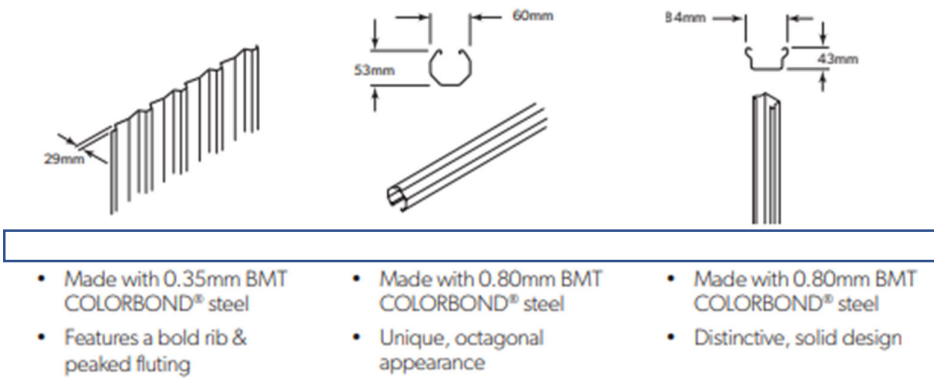

Annotation of panel and post profile above.



Annotation of color above. Please note – the existing panel fencing that was erected prior to purchase of the property was erected in this color choice. Extension of fencing in same color choice to match existing and blend in an non offensive manner with landscape.

Actual image of fencing panels seeking approval pictured below.

